



Artist Toolkit

Instruction Manual



Contents

System Introduction.....	2
File Introduction.....	3
Artist Toolkit GUI And Tool Introduction	4

Common Function

Open and Save File.....	6
Import and Open embroidery library.....	9
Common Functions	11
View Function	14
Basic Edit Tools	15
Environment Settings	16

Embroidery Setting

Embroidery Stitches	19
Embroidery Preview and Setting	72
Work Area Settings.....	80
Account Functions	82
Online Tutorial and Software Version	84
Check Update.....	85

Mode Functions

Edit Mode	88
Text Manager.....	104
Monogram	108
Paint Mode	110
Photo Stitch	118

Others

System Requirements	152
---------------------------	-----

Embroidery Pattern Chart

Embroidery Pattern Chart.....	154
-------------------------------	-----

System Introduction

This software can import other formats such as .dst, .pes and more, then will generate output of the embroidery system edit file (.qsd) and embroidery file (.zhs). The user interface can let users to operate through toolbar or pull down commands.

The system platform includes five major modules: Edit Mode, Text Manager, Monogram, Paint Mode, Photo Stitch.

This system provides digitization and editing capabilities, allowing you to freely create original embroidery designs.

You can combine embroidery patterns or apply knitting methods to pictures and text.

You can use the various sewing types provided to design more embroidery patterns, and produce customized patterns for embroidery machines.

File Introduction

Vector file:

The object drawn by the tools of "Drawing Module", including the outline and area of the satin, cache pattern, can change the color, stitch and stitch related parameters (stitch angle, stitch distance, thread distance .. etc.), can also edit the "line satin" path (by moving points, deleting points, adding points) to adjust the line satin shape.

Text file:

by inputting, deleting characters, editing text, specifying font and size.

Stitch file:

It is represented by a dashed frame. You can use the "Edit Point" function to move, delete, and add needle drop points, but you cannot change the stitching of the object outline and area.

※ "Vector files" and "text files" can be converted into "stitch files" through the function of "Convert to Embroidery Objects".

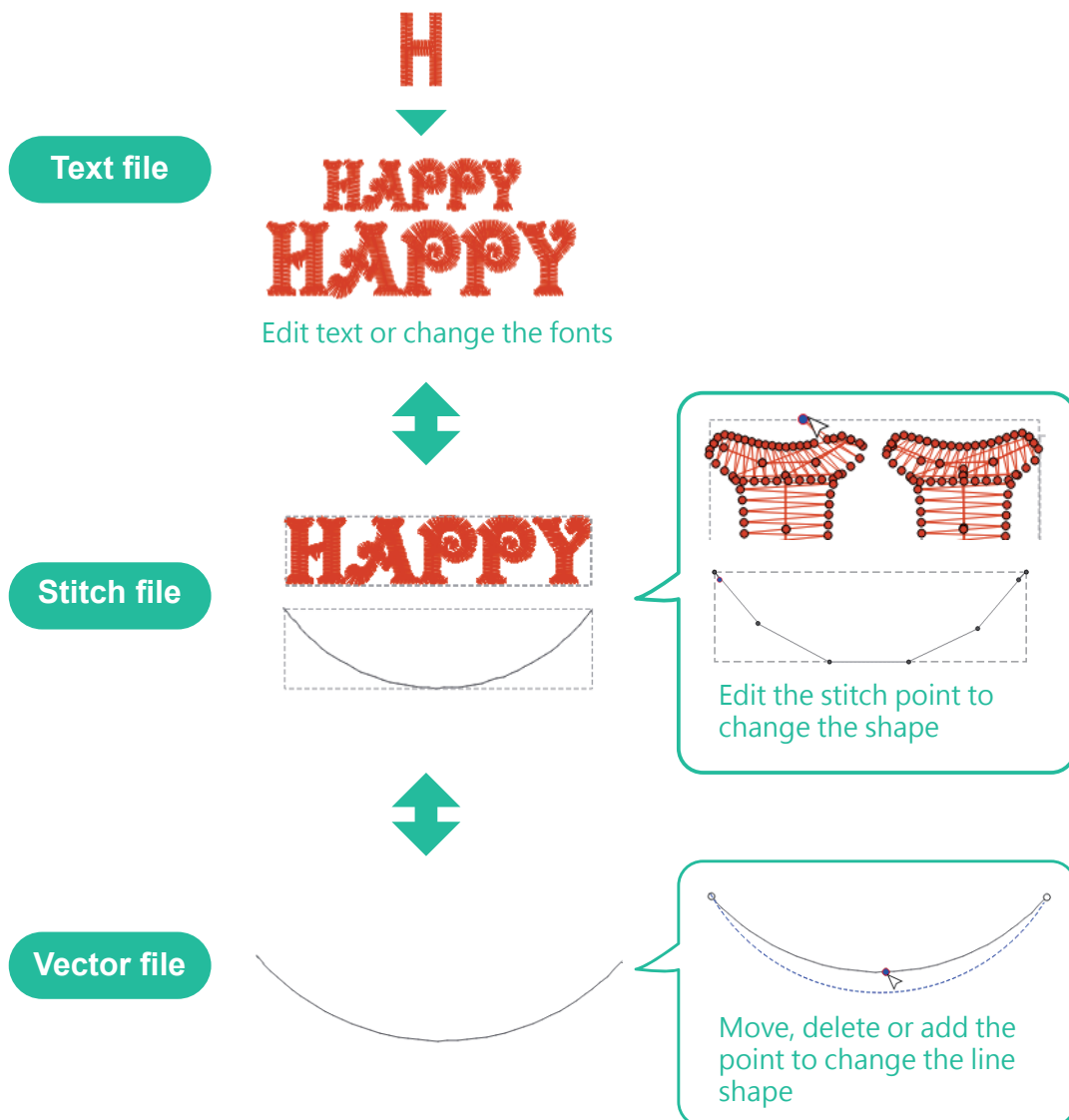

Artist Toolkit GUI And Tool Introduction

The main screen area of the program is as follows:

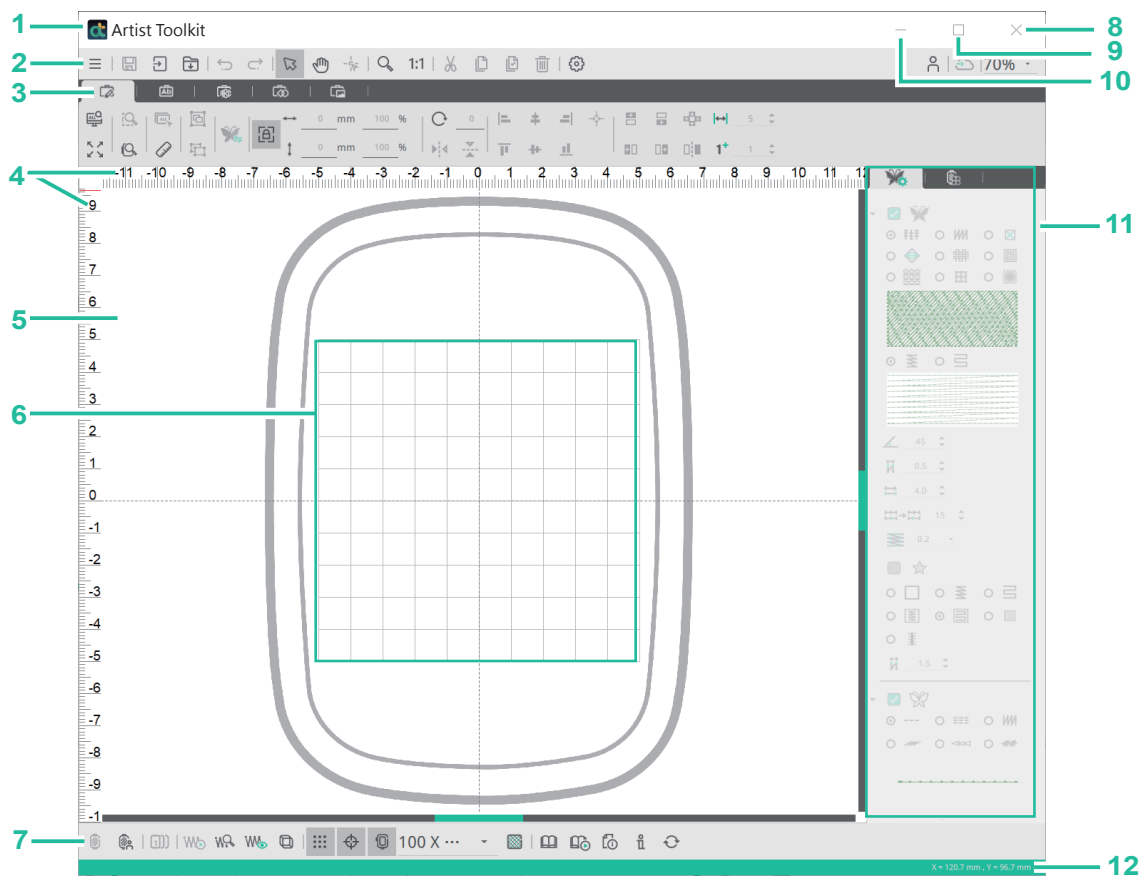

1. Title bar

Displays the icon, program and file's name.

2. Menu bar

All program functions can be selected from this menu bar.

3. Mode toolbar

Paint function to create, select, or edit patterns.

4. Ruler

5. Work area

6. Edit area

For users to edit design patterns and create embroidery stitches. The path used is the part that can actually be stored.

7. Toolbar

A quick cache for most used function tabs.

8. Close button

9. The Maximize button

10. The Minimize button

11. Embroidery setting

Customize embroidery parameters/color settings.

12. The status bar

Show the pattern size, zoom scale and coordinates of the current mouse cursor position.

Common Function

Open and Save File

● File



New File

Path: [File]→<New File>

Description: The system can be restored to the default state when adding files.

Steps: Click on the menu [File] and click on <New File> from the dropdown menu.

Shortcut key: Ctrl+N (Windows system) / Command+N (OS system)



Open File

Path: [File]→<Open File...>

Description:

Open the system edit file (.qsd) when starting the embroidery design process.

Steps:

1. Click on the menu [File] and then click on <Open File...>
2. A window will pop-up and select the file where the file is stored.
3. Select the file and click to open the old file (Ctrl+O), or double-click the icon of the file.

Shortcut key: Ctrl+O (Windows system) / Command+O (OS system)



Save File

Path: [File]→<Save File...>

Description: Save the edit file (.qsd) during the embroidery design process.

Steps: Click on the menu [File] and click on <Save File>

Shortcut key: Ctrl+S (Windows system) / Command+S (OS system)



Save File as

Path: [File]→<Save File as...>

Description:

Save the edit file (.qsd) during the embroidery design process or save as the actual format that the embroidery machine can read (*.qsd /*.zhs/* .exp).

Steps: Click on the menu [File] and click on <Save File as>

Export Image

Path: [File]→<Export Image...>

Description: Export the design as a drawing file.

Steps:

Export all

Click on the menu [File] and click on <Export Image...>, then click on <Save> and set the storage path, and finally click on <Save>.

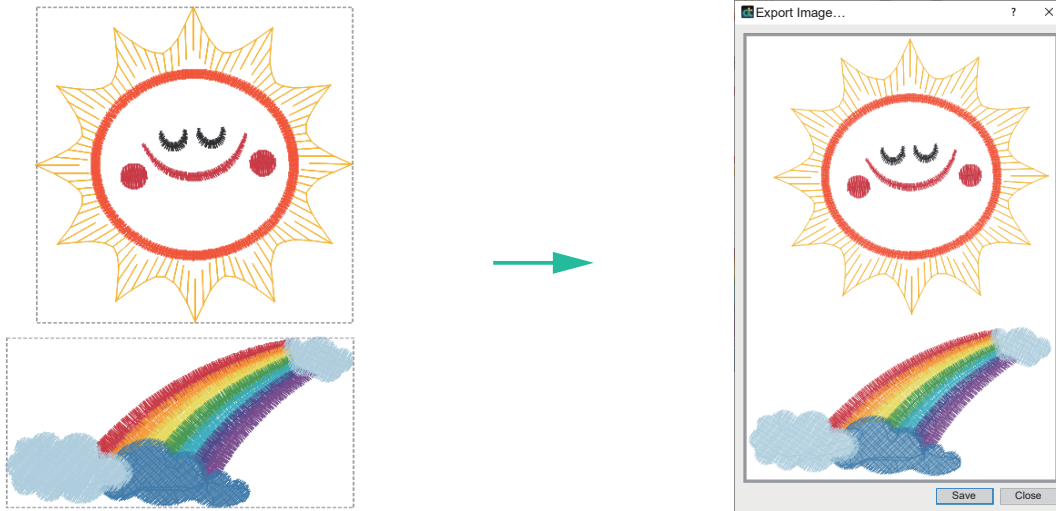

Selective export

1. When there are multiple image files in the editing area, click the left mouse button to select the object to be saved, then click the menu [File] and select <Export Image File>.
2. At the bottom of the window, click the <Select Objects> or <All Objects> option, click <Save> to set the storage path, and finally click <Save>.

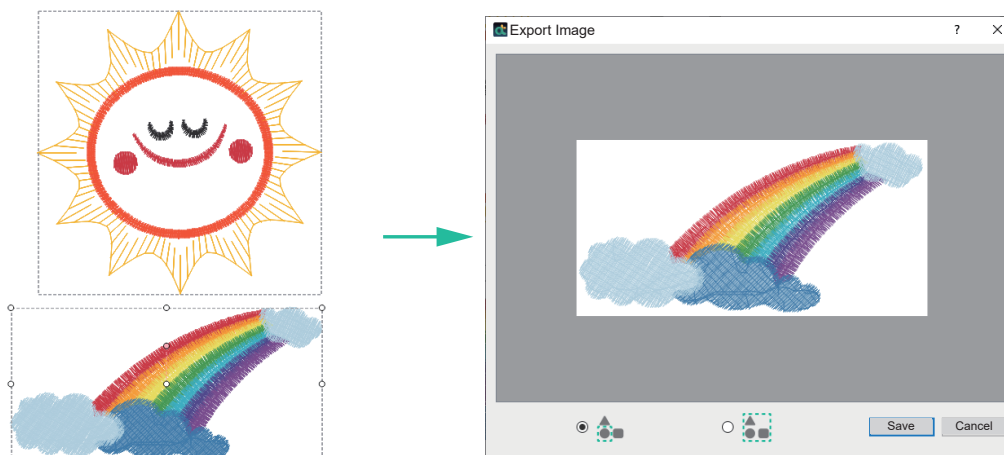



Print

Path: [File]→<Print Preview>

Description:

Preview and print the content of the currently opened file. The pattern is placed in center. The preview printing function provides printing, zoom, one-page, two-page, four-page options and other options for users to use according to their needs.

In addition to the pattern, the content display includes: file name, date, file name, embroidery pattern size, embroidery frame size, number of stitches, embroidery thread color, etc., for users to print for reference.

Steps:

Click the menu [File] and select <Print> and the preview print screen appears. Click <Print>, the print screen appears, select the printer, print range, number of copies and press the button to execute printing.

Shortcut key: Ctrl+P (Windows system) / Command+P (OS system)



Exit

Path: [File]→<Exit>

Description: Shut down the system.

Steps: Click on the menu [File] and select <Exit>.

Shortcut key: Ctrl+F4 (Windows system) / Command+F4 (OS system)

Import and Open embroidery library

● Save Embroidery File



Save File

Path: [File]→<Save File>

Description: Save the edit file (.qsd) during the embroidery design process.

Steps: Click on the menu [File] and click on <Save File>

Shortcut key: Ctrl+S (Windows system) / Command+S (OS system)



Open embroidery library

Path: Toolbar <Open Embroidery library>

Description:

The built-in embroidery patterns in the software include categories such as flowers, plants, animals, trims, totems, sports, Christmas, Halloween, landscapes, household goods, etc., which can be imported and added to the current design page.

Steps:

Click on the toolbar [Open Embroidery library], a window will pop-out, click the desired embroidery image, and double-click the mouse twice.

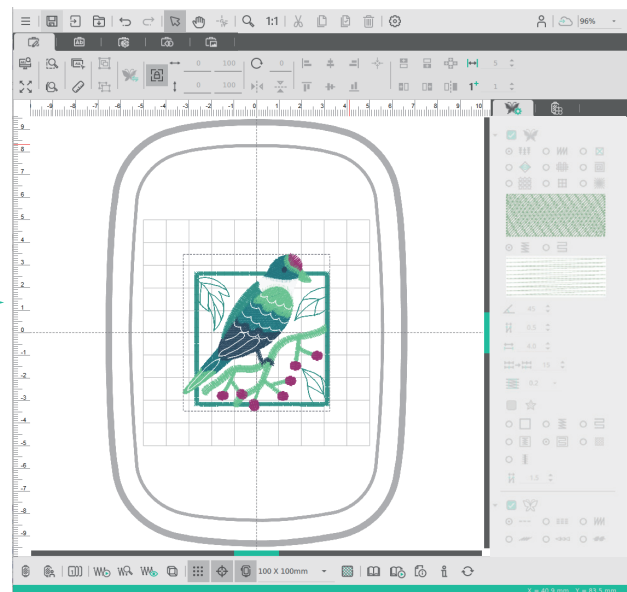
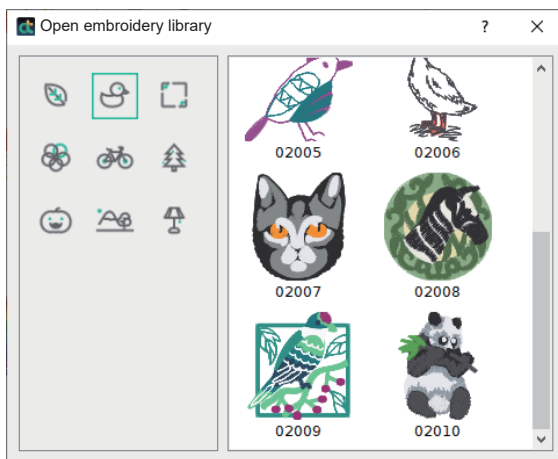



Import



Import Embroidery File

Path: Toolbar <Import>→<Import Embroidery>

Description:

The supported embroidery file formats includes ZengHsing(.zhs/.zhx), Tajima(.dst), Brother(.pes/.pec), Bernina(.exp), Janome (.jef/.sew), Pfaff(.pcs/.Vp3), Singer(.xxx) and Husqvarna(.hus/.vip) can be imported and added to the current design page.

Steps:

Click on the toolbar [Import Embroidery], a window will pop-out, follow the path, and place the desired embroidery image. Drag the embroidery file to the window, you can also directly import the embroidery file.



Import Image File

Path: Toolbar <Import>→<Import Image File>

Description:

can be imported *bmp 、 *png 、 *jpg 、 *jpeg and added to the current design page.

Steps:

Click on the toolbar [Import Image File], a window will pop-out, follow the path, and place the desired image. Double click to import or can click on (Open File) to import file.



Import SVG File

Path: Toolbar <Import>→<Import SVG File>

Description:

can be imported SVG file to the current design page.

Steps:

Click on the toolbar [Import SVG File], a window will pop-out, follow the path, and place the desired image. Double click to import or can click on (Open File) to import file.

Common Functions

Undo

Path: Toolbar <Undo>

Description:

The system saves the data changes in the editing process, and provides the user with the data content of the previous editing action.

Steps: Click the menu <Undo>.

Shortcut key: Ctrl+Z (Windows system) / Command+Z (OS system)

Redo

Path: Toolbar <Redo>

Description:

The system saves the data changes during the execution of the "Recover" function, and provides users with the action before the last "Recover".

Steps: Click on the menu <Redo>.

Shortcut key: Ctrl+Y (Windows system) / Command+Y (OS system)

Select

Path: Toolbar <Select>

Description: Select the object.

Steps:

1. The icon of the cursor will switch to .
2. Click the pattern you want to select, or drag the cursor across the pattern(s) you want to select.
When dragging the cursor, all the patterns within in the selection area will be selected. Control points will appear around the selected pattern, and the status bar will display the pattern size (width and height).

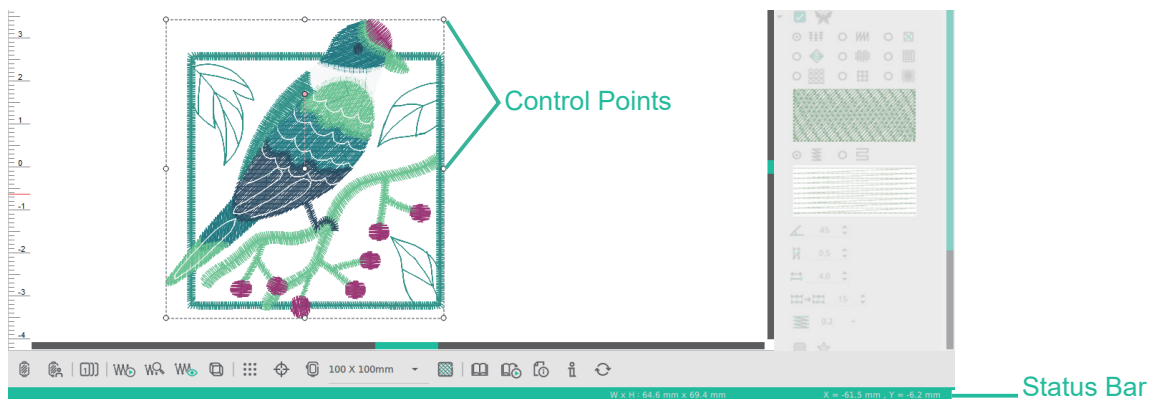

3. Object movement can be combined with the "Ctrl" key to move vertically or horizontally, and you can also hold down the "Ctrl" key to add or remove objects.
4. To cancel the selected pattern, select a different pattern, click on a blank area of the design page or click any other button in the toolbar.

Shortcut key:

move objects vertically or horizontally, add or remove patterns. Ctrl (Windows system) / Command (OS system)





Path: Toolbar <Pan>

Description:

When designing an embroidery pattern, after the picture is zoomed to the required size, you can use "Pan" to move the pattern.

Steps:

1. The icon of the cursor will switch to .
2. Press and hold the left button of the mouse, the icon of the cursor will switch to , and then drag the mouse to move the pattern.
3. To cancel, click any other button in the toolbar.

Edit Point

Path: <Edit Points>

Description:

The node of the object can be moved, deleted or added. (Including vector file, curve or stitch file)

Steps:

1. Click on the object you want to edit, and then click on <Edit Points> to display the object nodes.
2. Move the cursor over the node you want to change its position. When the shape of the cursor changes to , hold down the left mouse button and drag the node to the desired position.

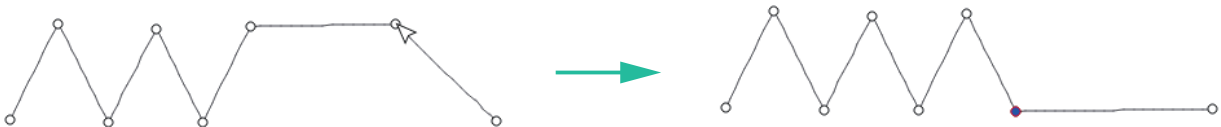

3. To add a node to the object, move the cursor over the line segment where you want to add a node. When the shape of the cursor changes to , double-click the mouse to add a node.

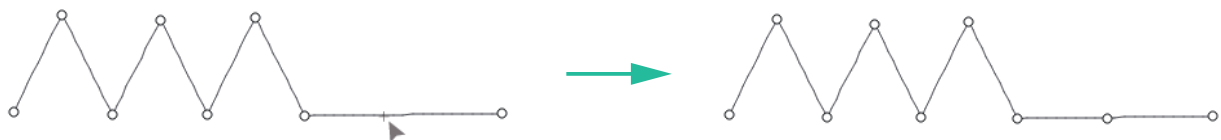

4. To delete a node on the object, click on the node you want to delete and press "Delete" on the keyboard to delete, or click on the toolbar and click on <Delete> to delete the file.

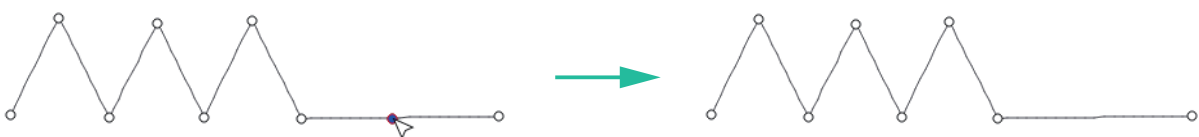

- ※ When the embroidery stitch file is in a group state, the editing and node functions cannot be used, and the editing and node functions can be performed only after the group is disbanded.

View Function



● Zoom Tool

Zoom

Path: Toolbar <Zoom>

Description: Enlarge or reduce the display size of the work area on the screen.

Steps:

1. Click <Zoom> on the toolbar, and the cursor will appear . Press the left button of the mouse on the design panel to select the area you want to zoom in.
2. Click <Zoom> on the toolbar, and press the left button of the mouse, the cursor will appear . Each click will zoom in by 25%, up to 2000%.
3. Click the <Zoom> on the toolbar, and press the right mouse button, and the cursor will appear . Each click will zoom out by 25%, and the minimum zoom rate can be 25%.

Shortcut key:

Press the "Ctrl" button with the mouse wheel or the "Ctrl" button with the "+/-" button to zoom in/out the window. Ctrl (Windows system) / Command (OS system)

1:1 Zoom Original

Path: Toolbar <Zoom Original>

Description: Restore the display size of the work area on the screen.

Steps: Click on <Zoom Original> on the toolbar to restore the view size.

Shortcut key: Ctrl+0 (Windows system) / Command+0 (OS system)

Basic Edit Tools



Cut

Path: Toolbar <Cut>

Description:

Remove the editing object (vector pattern or stitch pattern) selected, and temporarily store a copy of the data, which can be used to "paste" the data immediately.

Steps: After clicking the pattern you want to cut, select the toolbar and click <Cut>.

Shortcut key: Ctrl+X (Windows system) / Command+X (OS system)



Copy

Path: Toolbar <Copy>

Description:

Copy the object selected and will temporarily store a copy of the data, which can be used as an immediate data "paste" function.

Steps:

After clicking the pattern to be copied, select the toolbar and click <Copy> to copy a pattern.

Shortcut key: Ctrl+C (Windows system) / Command+C (OS system)



Paste

Path: Toolbar <Paste>

Description: "cut" or "copy" data copy into the system editing workspace.

Steps:

After performing the "cut" or "copy" action, click on the toolbar and click <Paste> to paste the pattern.

Shortcut key: Ctrl+V (Windows system) / Command+V (OS system)



Delete

Path: Toolbar <Delete>

Description: Delete the editing object selected.

Steps:

After click on the pattern to be deleted, click on <Delete> in the toolbar to delete the file.

Shortcut key: Delete (Windows system) / Function+delete (OS system)

Environment Settings

● Function Settings Introduction

⚙️ Function Set

Path: Toolbar <Grid>

Description: Below will introduce how to set Grid, Language, Auto Save.

📏 Grid

Path: Toolbar <Grid>

Description:

Set the grid size of the embroidery area, and show the grid in line or point type.

1. Show Grid: Line, Point

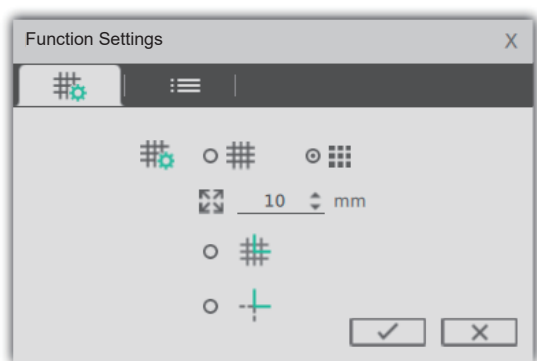
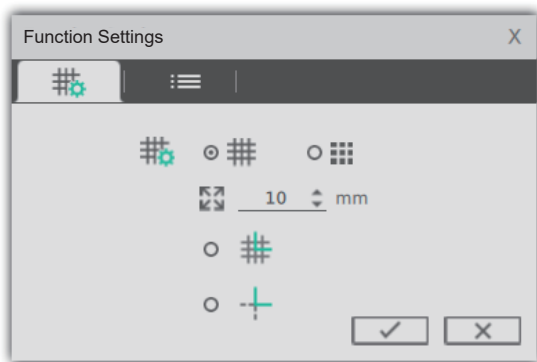

2. Grid Size (mm): 1~25 mm

3. Snap To Grid select whether to snap to the grid or not; if the snap function is turned on, the grid in lines or points will be automatically snapped to when creating an object or moving or scaling the object.

Steps:

Click the toolbar [Settings], select the grid tab, click <Grid>, and enter the grid size, check the grid lines or points, and check whether to align the grid lines.



Language

Path: Toolbar <Settings>→<Option>→<Language>

Description: Set country language.

Steps:

Click the toolbar [Settings], select the option tab, click on menu, and select the desired language.



Auto Save

Path: Toolbar <Settings>→<Option>→<Auto Save>

Description:

The file will be automatically saved according to the customized time. When the computer is turned off or the software is forcibly closed, the file can be saved when the software is reopened.

Steps:

Click on the toolbar [Settings], select the option tab, tick on automatic storage and enter the value.

※ 1(minimum)~1(default)~60(maximum), Unit: Minutes

The background is a dark blue gradient with several overlapping, wavy, layered shapes in lighter shades of blue, creating a sense of depth and movement. The shapes are organic and fluid, resembling liquid or smoke. The text is centered in the middle of the composition.

Embroidery Setting

Embroidery Stitches

● Pattern Settings

Stitch Effect

Path: <Stitch Effect>

Description:

It is divided into area sewing and contour sewing settings. When you click on the function icon (the background color of the icon is inverted), you can select the stitch method for the selected vector pattern object and set the secondary embroidery parameters, including angle, thread pitch, stitch length, staggered way...etc.

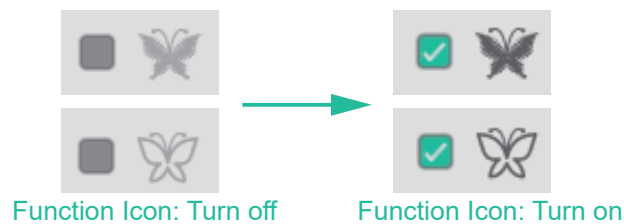

Region Sew

Steps:

1. Click on the object.
2. The preset sewing area mode is  . When the icon is clicked again, it will cancel the sewing area  .

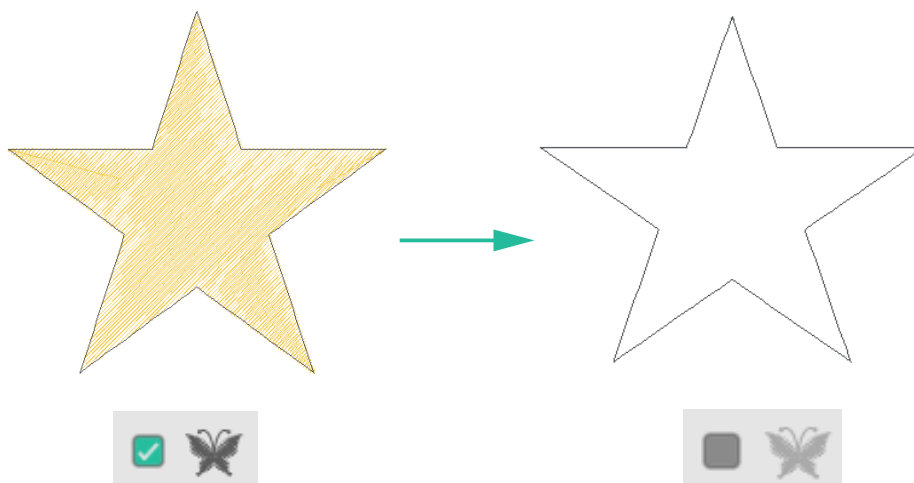

Complex Fill Stitch

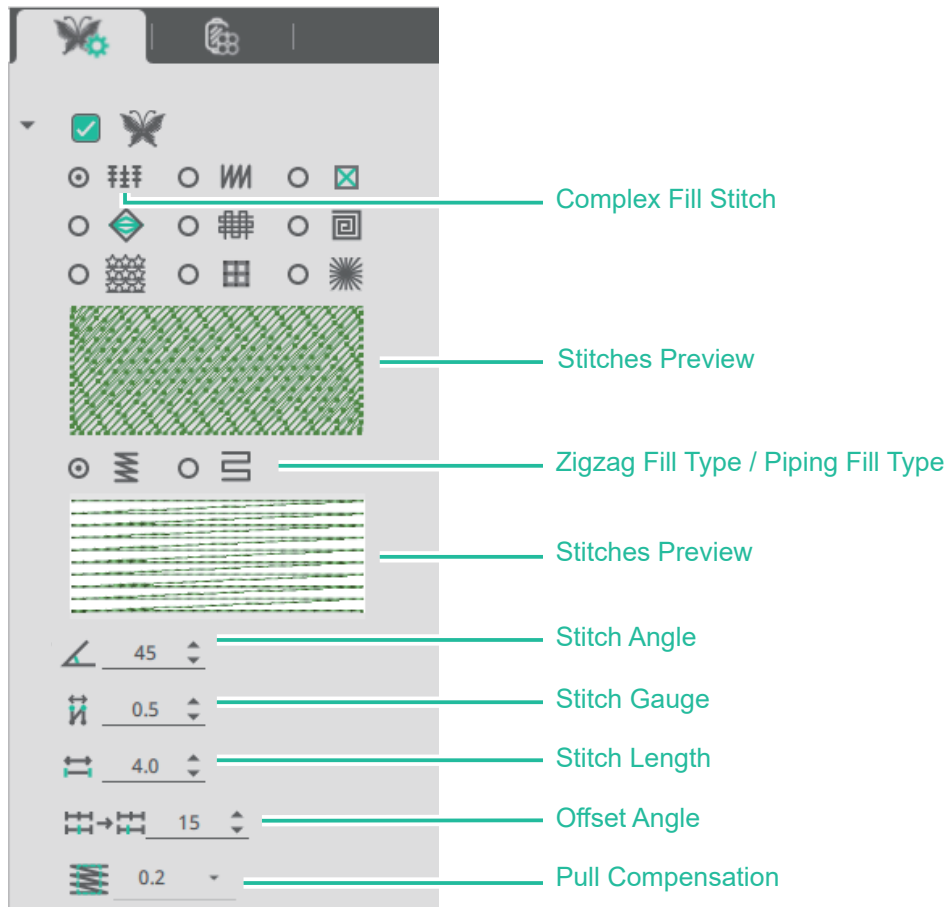

Complex Fill Stitch distinguish between the following two embroidery methods:

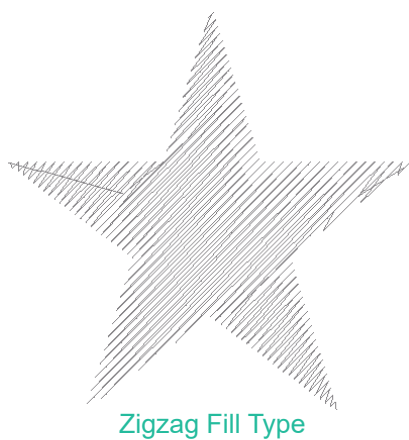

※ The parameters below can be adjusted and set according to personal preference

 Stitch Angle:

Change the direction of the stitching method, 45 (default), unit: degree.

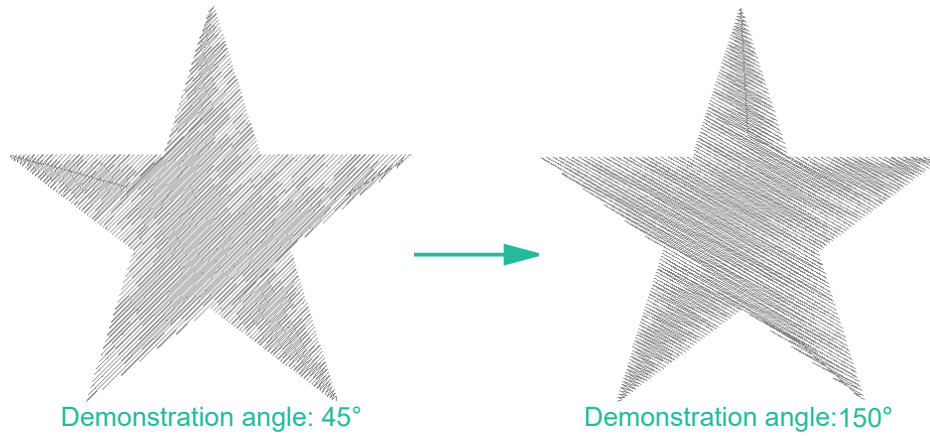

 Stitch Gauge:

The distance between two lines, 0.5 (default), unit: mm.

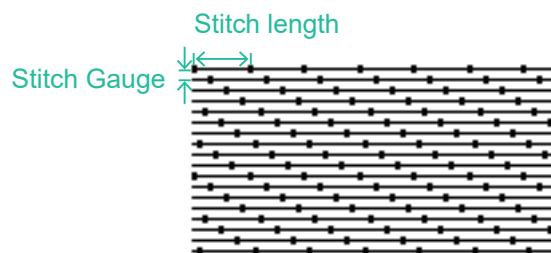

 **Stitch Length:**

Adjust the distance between two stitches, 4.0 (default), unit: mm.

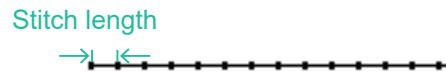

 **Offset Angle:**

Adjust the offset of the parallel staggered needle position of the upper row and the lower row to produce different embroidering changes, 15 (default), unit: degree.

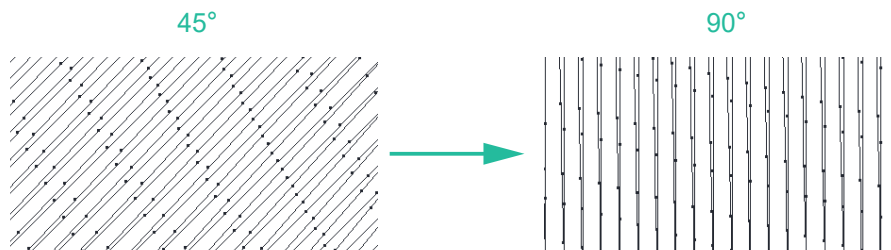

 **Pull Compensation:**

Adjust the stitch expansion value of the selected area, which can be used to prevent the fabric from shrinking during embroidery and cause the embroidery pattern to be deformed. Range: 0, 0.2 (default), 0.35, 0.4, unit: mm.

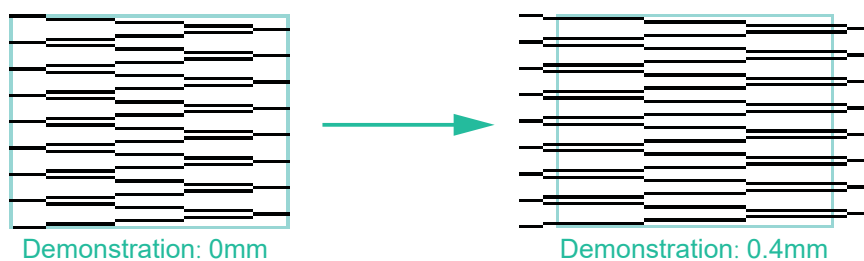

W Satin Fill Stitch

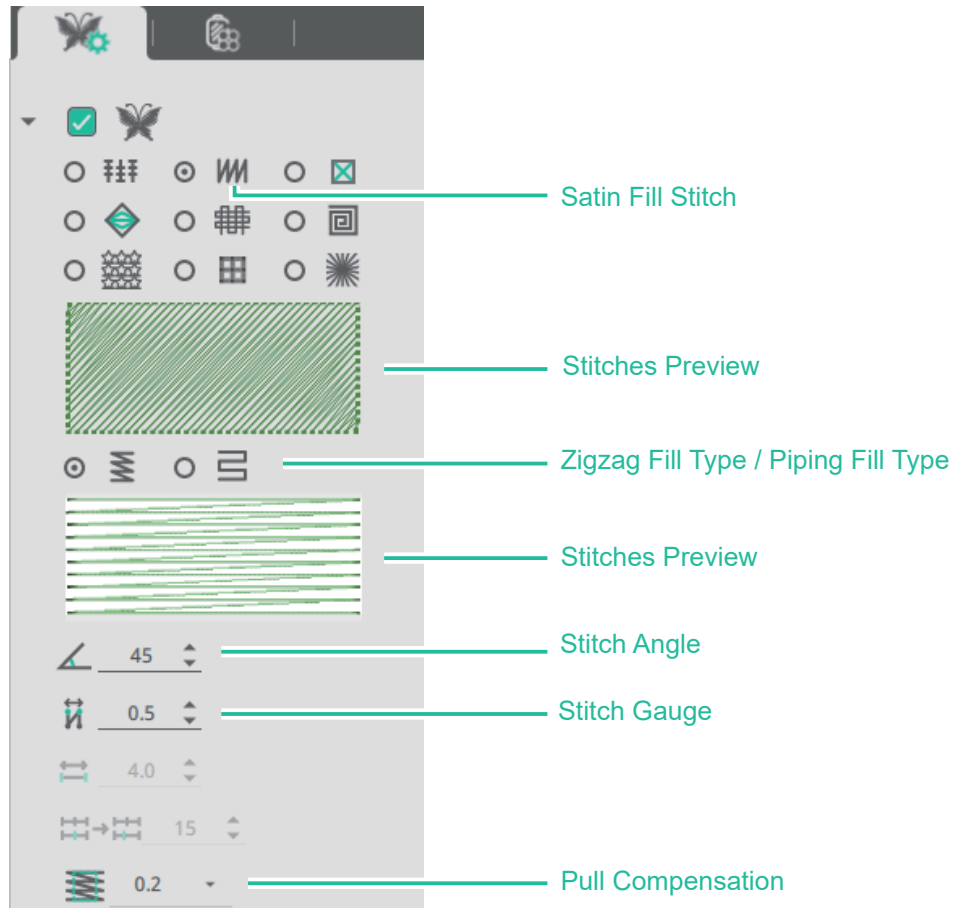

Satin Fill Stitch distinguish between the following two embroidery methods:

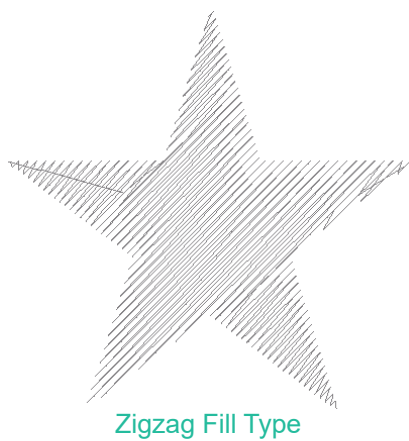

※ The parameters below can be adjusted and set according to personal preference

 Stitch Angle:

Change the direction of the stitching method, 45 (default), unit: degree.

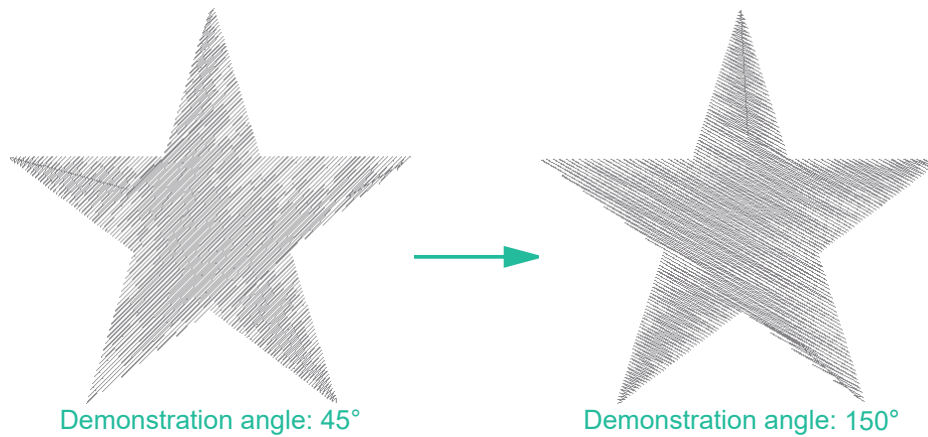

 Stitch Gauge:

The distance between two lines, 0.5 (default), unit: mm.

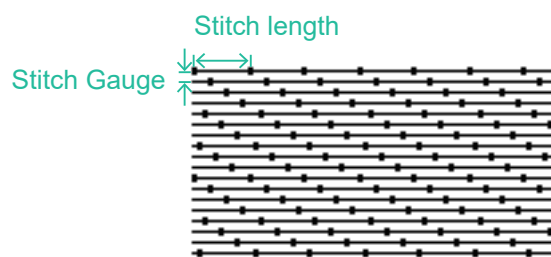

 Pull Compensation:

Adjust the stitch expansion value of the selected area, which can be used to prevent the fabric from shrinking during embroidery and cause the embroidery pattern to be deformed. Range: 0, 0.2 (default), 0.35, 0.4, unit: mm.

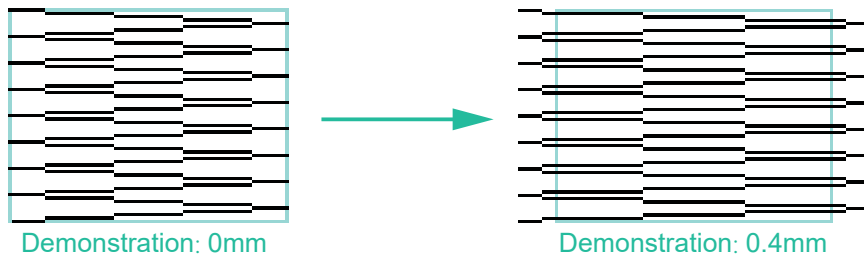

Cross Stitch

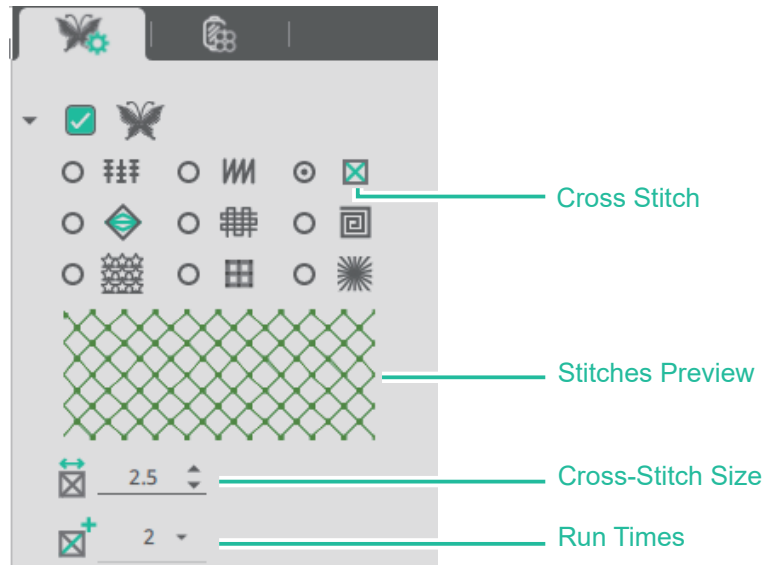

※ The parameters below can be adjusted and set according to personal preference

Cross-Stitch Size:

Set the size of the cross-stitch grid, 2.5 (default), unit: mm.

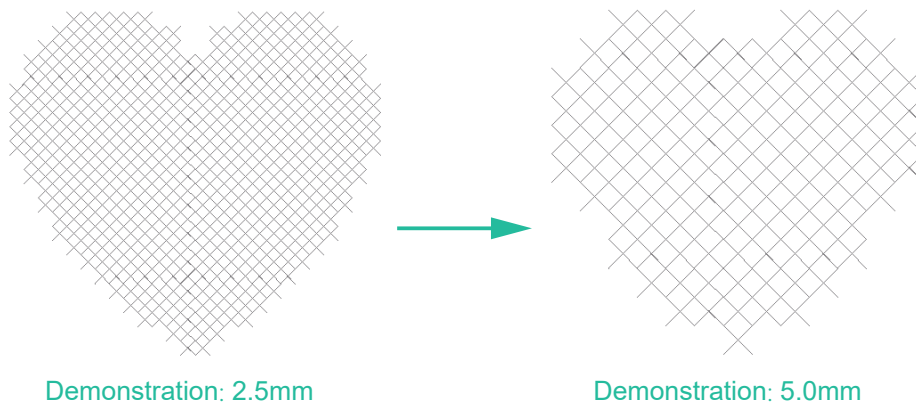

Run Times:

Set the run times of cross-stitch sewing, 2(default), unit: times.

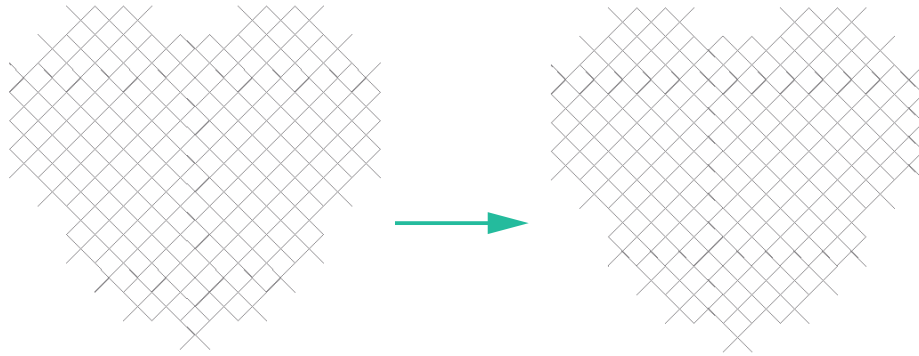

Piping Stitch

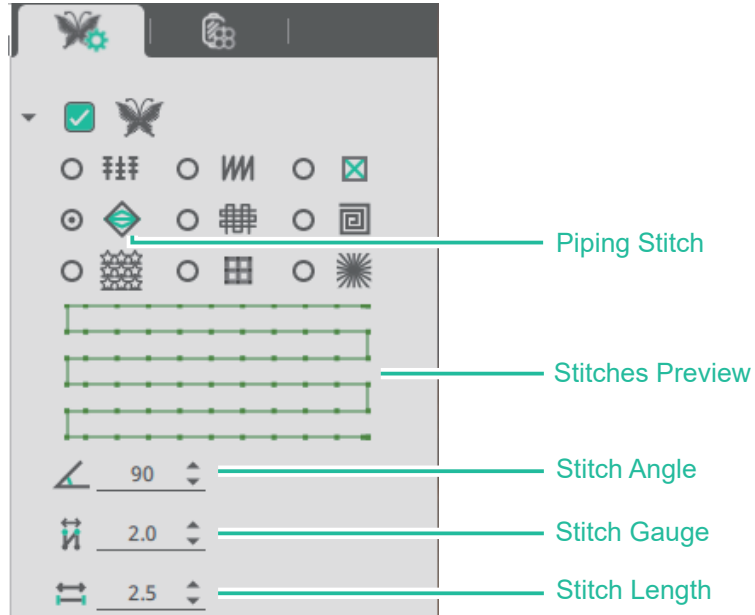

※ The parameters below can be adjusted and set according to personal preference

 Stitch Angle:

Change the direction of the stitching method, 90 (default), unit: degree.

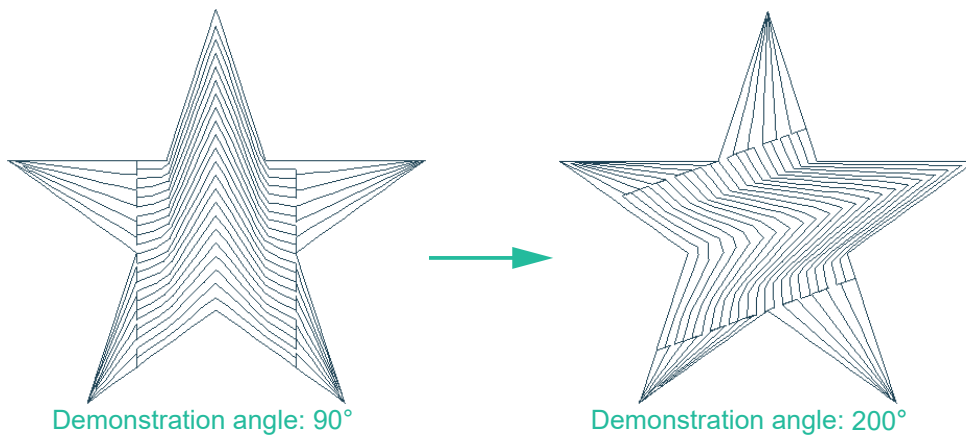

 **Stitch Gauge:**

The distance between two lines, 2.0 (default), unit: mm.

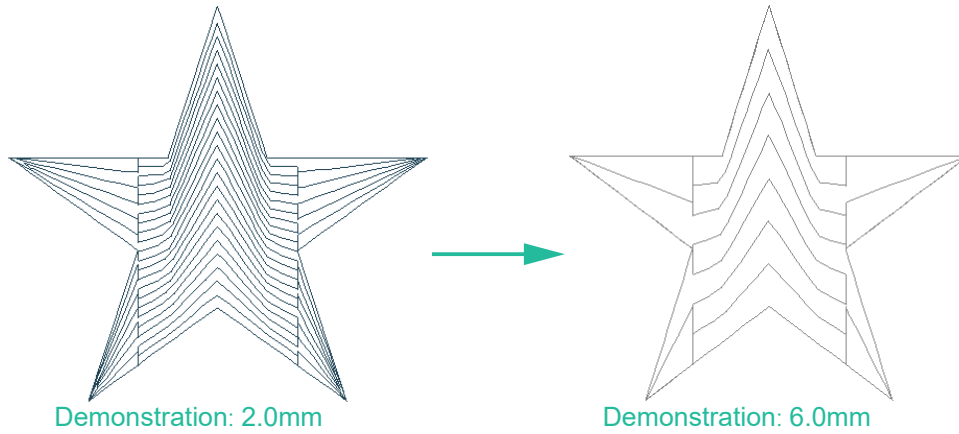

 **Stitch Length:**

Adjust the distance between two stitches, 2.5 (default), unit: mm.

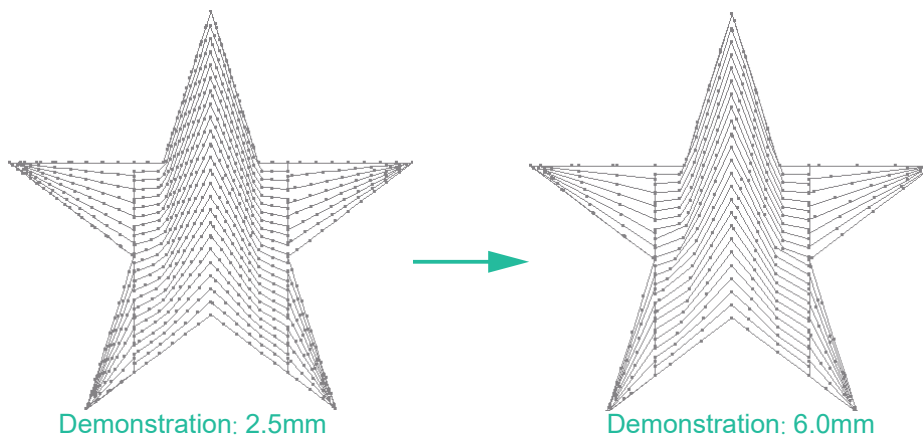

Net Fill Stitch

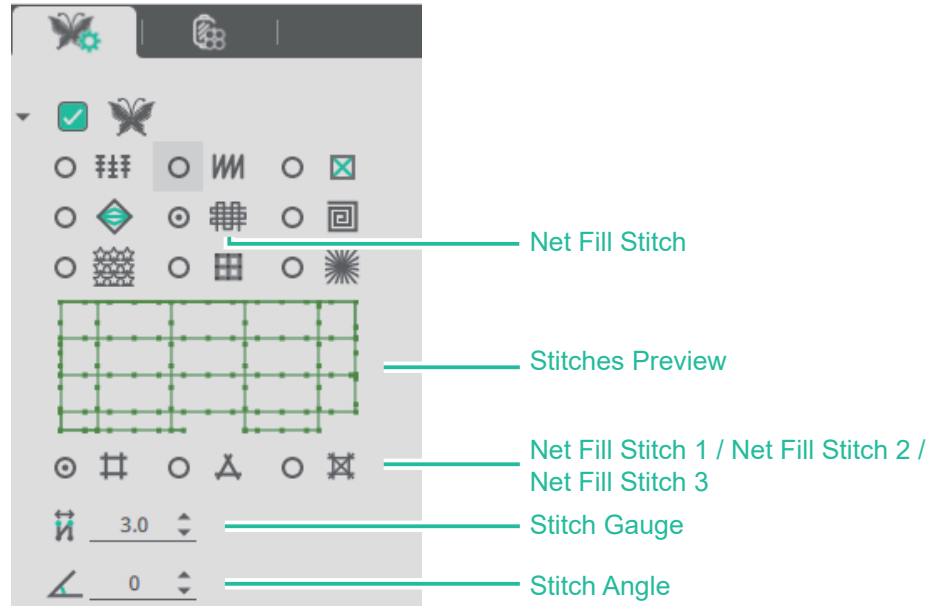

Net Fill Stitch can be divided into three types of stitches:

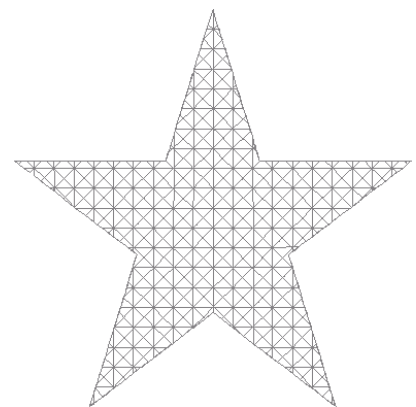
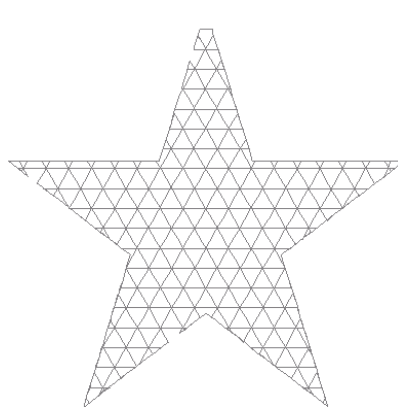
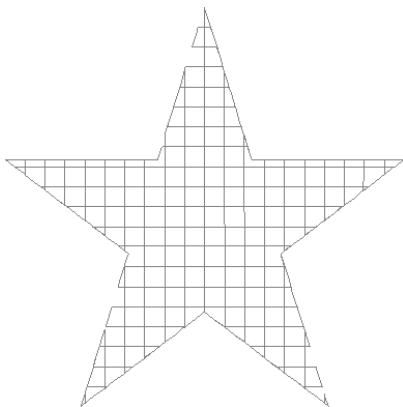

※ The parameters below can be adjusted and set according to personal preference

 Stitch Gauge:

The distance between two lines, 3.0 (default), unit: mm.

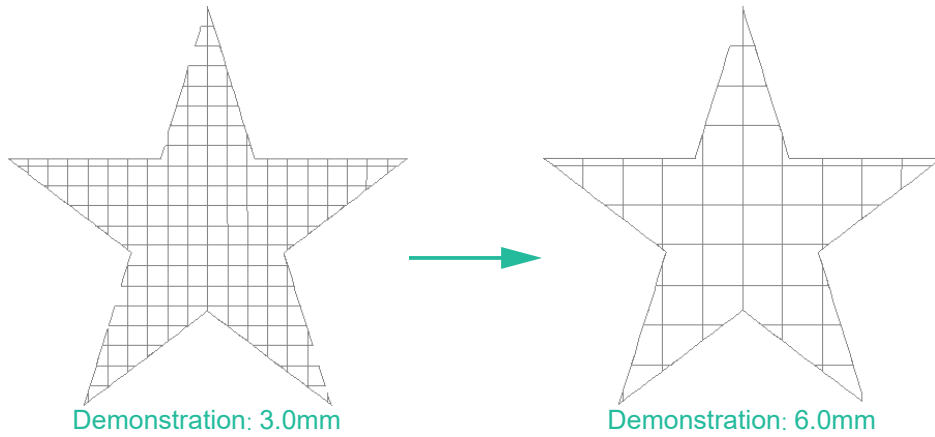

 Stitch Angle:

Change the direction of the stitching method, 0 (default), unit: degree.

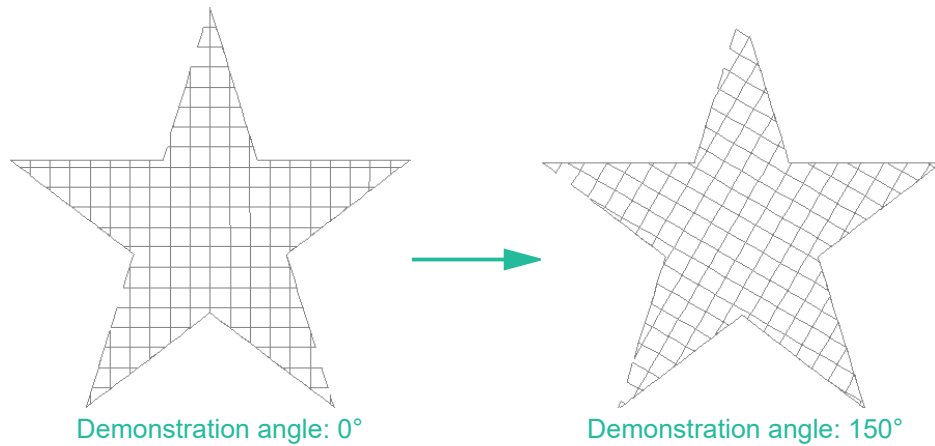

Spiral Stitch

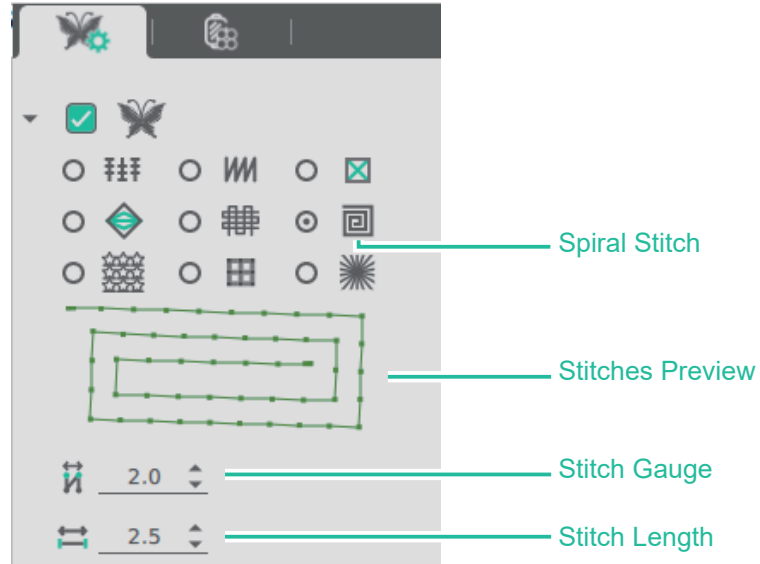

※ The parameters below can be adjusted and set according to personal preference

 Stitch Gauge:

The distance between two lines, 2.0 (default), unit: mm.

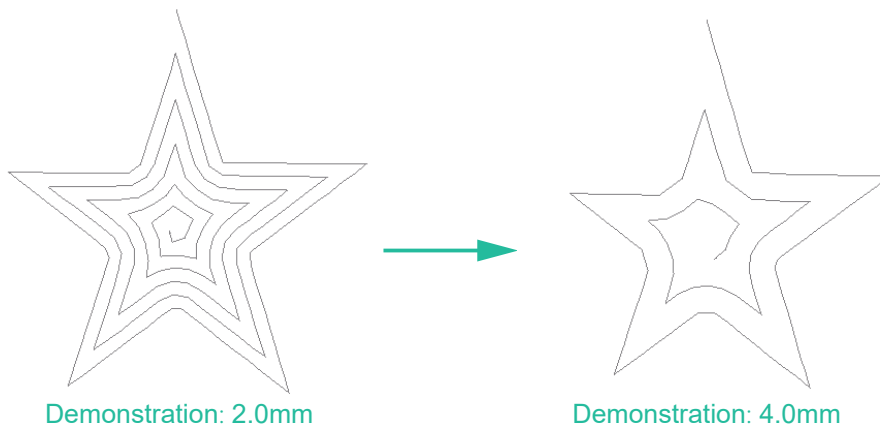

 Stitch Length:

Adjust the distance between two stitches, 2.5 (default), unit: mm.

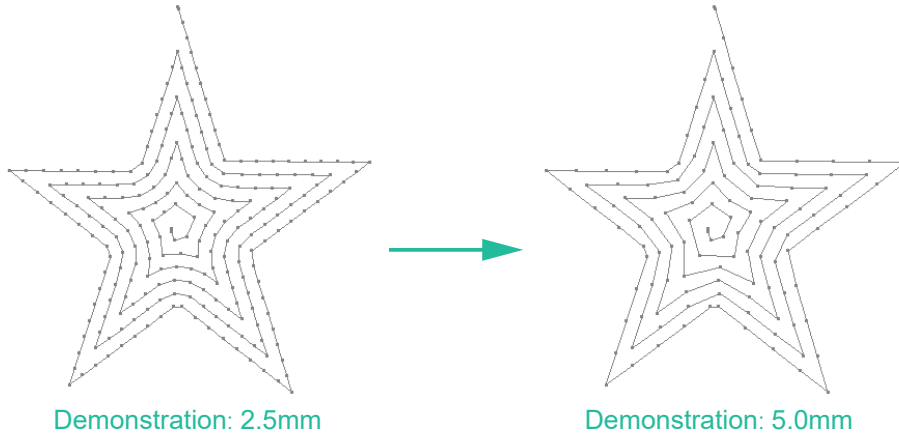



Motif Fill Stitch

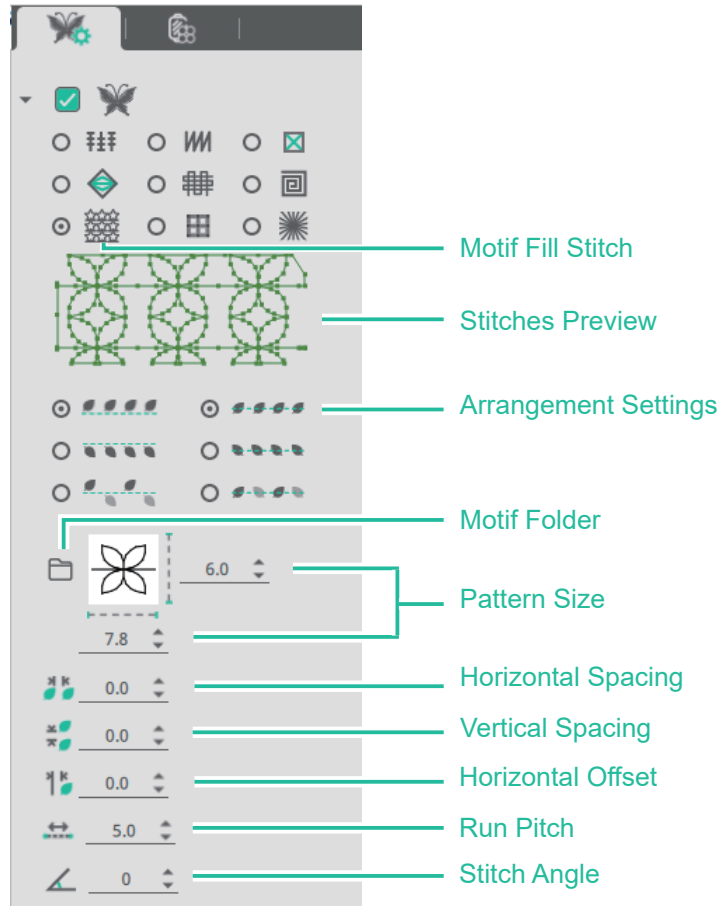

Motif stitch distinguish between the following six arrangement setting:

Horizontal arrangement (default): The Motif pattern embroidery are arranged upward along the horizontal axis.



Horizontal mirror : Arrange the Motif pattern embroidery downward along the horizontal axis.



Horizontal stagger : The Motif pattern embroidery are arranged one up and one down along the horizontal axis.

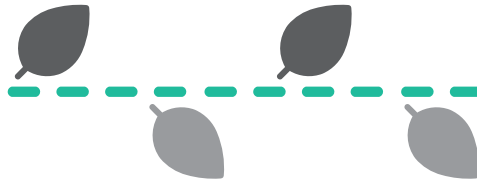

Vertical arrangement (default): The Motif pattern embroidery are arranged to the right along the vertical axis.



Vertical mirror : Arrange the Motif pattern embroidery to the left along the vertical axis.



Vertical stagger : The Motif pattern embroidery are arranged alternately on the right and left along the vertical axis.



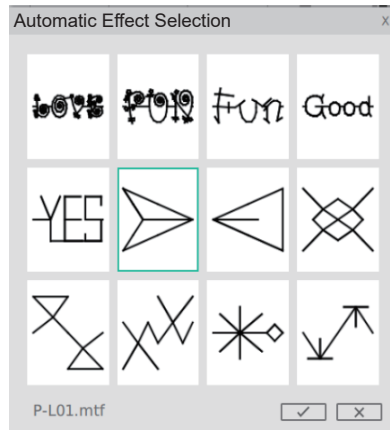

📁 Motif Folder:

Pattern embroidery pattern list.



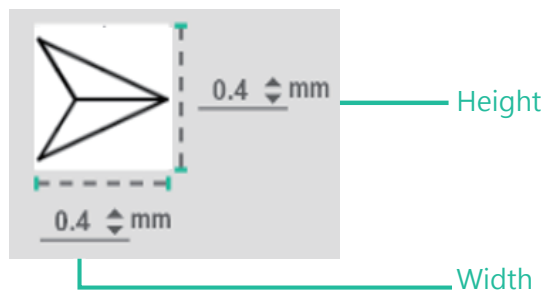

※ The parameters below can be adjusted and set according to personal preference
Pattern size: Set the height size, width size, unit: mm.

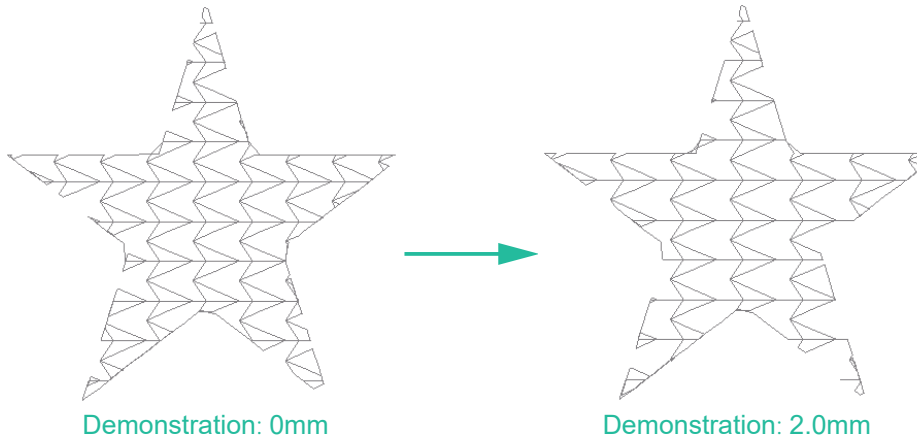

 Horizontal Spacing:

Setting of horizontal spacing of Motif fill stitch pattern, 0 (default), unit: mm.



 Vertical Spacing:

Setting of vertical spacing of Motif fill stitch pattern, 0 (default), unit: mm.

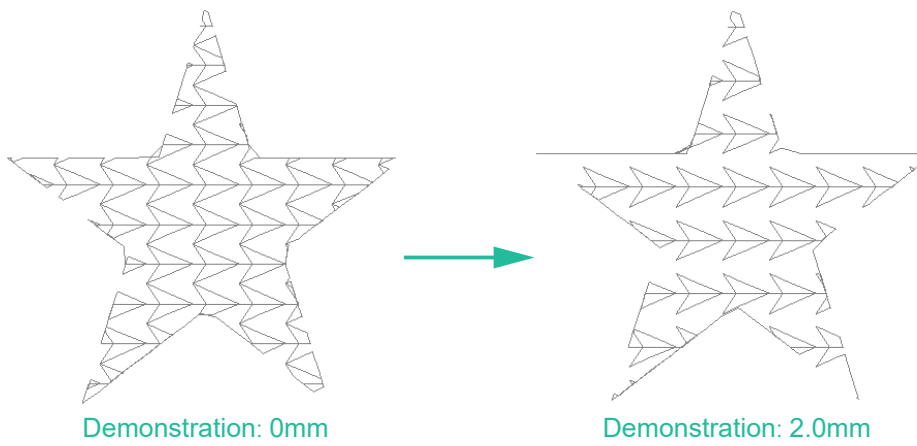

 Horizontal Offset:

Setting of horizontal offset of Motif fill stitch pattern, 0 (default), unit: mm.

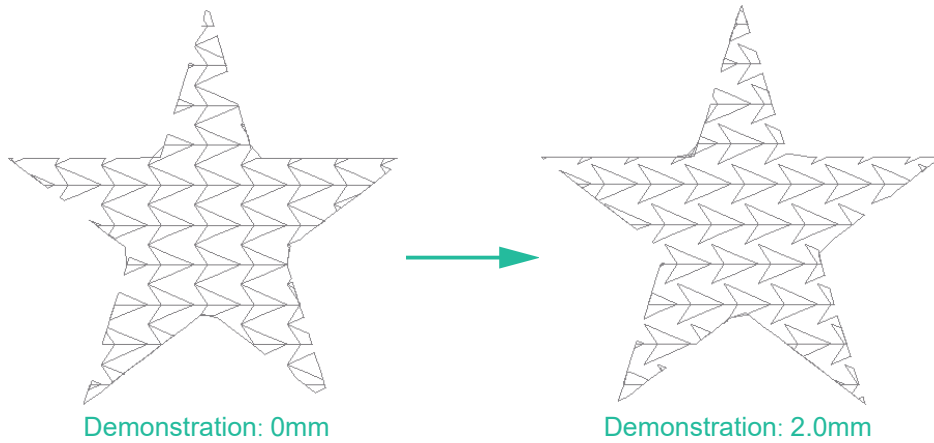

 Run Pitch Setting:

Stitch length judgment value setting for pattern embroidery, 5.0mm (default), unit: mm.

Set the stitch distance for a pattern embroidery to 2.0mm. If the stitch distance in a single pattern is greater than 2.0mm, the needle drop point will increase.

Not exceeding the stitch distance setting of 2.0mm, will not increase needle points

Exceeding the stitch distance setting of 2.0mm, will increase needle points (see in the arrow)

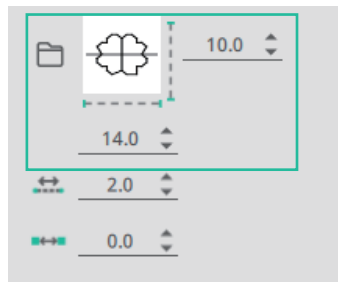
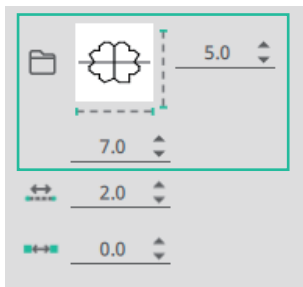
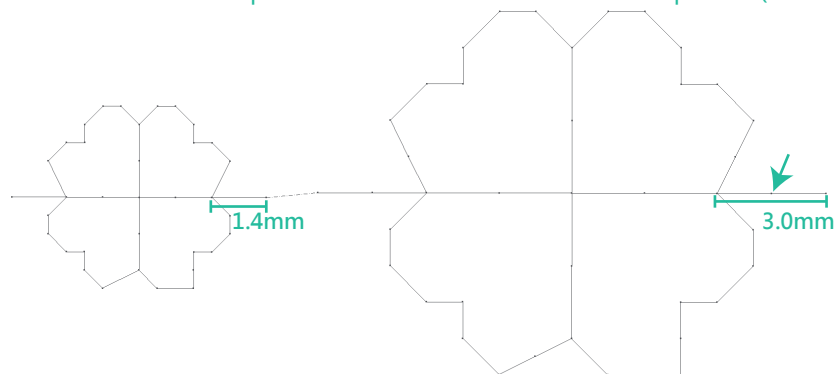

 Stitch Angle:

Change the direction of the stitching method, 0 (default), unit: degree.

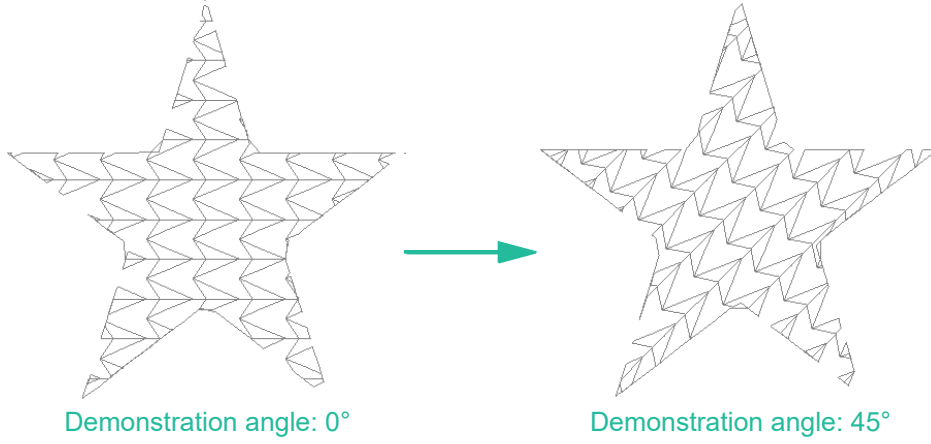

Zigzag Net fill stitch

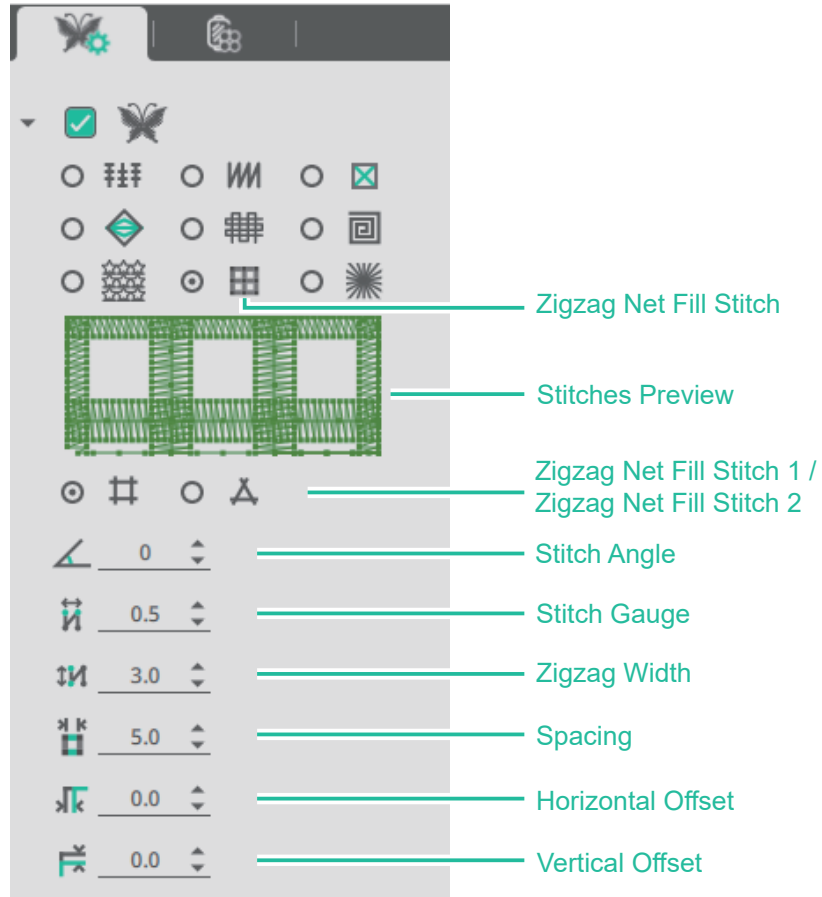

Zigzag net fill stitch is divided into two types of stitches

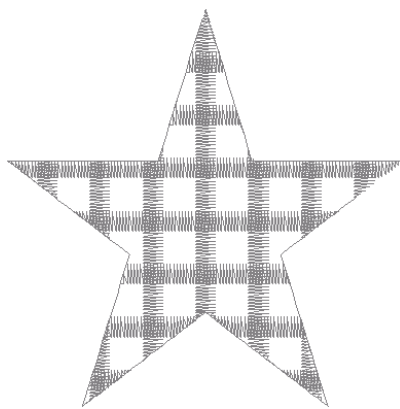

Zigzag Net Fill Stitch 1

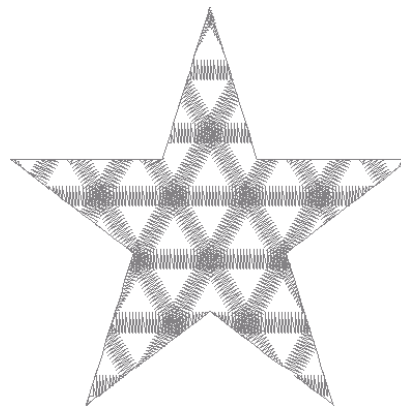

Zigzag Net Fill Stitch 2

※ The parameters below can be adjusted and set according to personal preference

 Stitch Angle:

Change the direction of the stitching method, 0 (default), unit: degree.

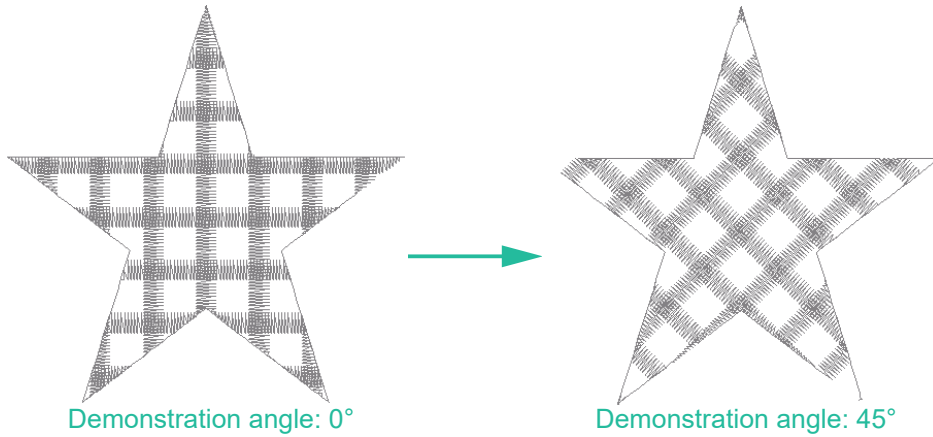

 Stitch Gauge:

The distance between two lines, 0.5 (default), unit: mm.

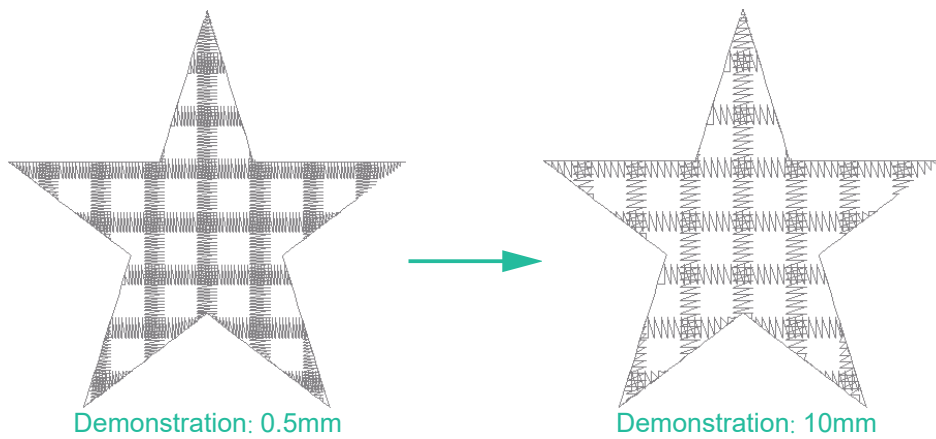

 Zigzag Width:

Zigzag width setting, 3 (default), unit: mm.

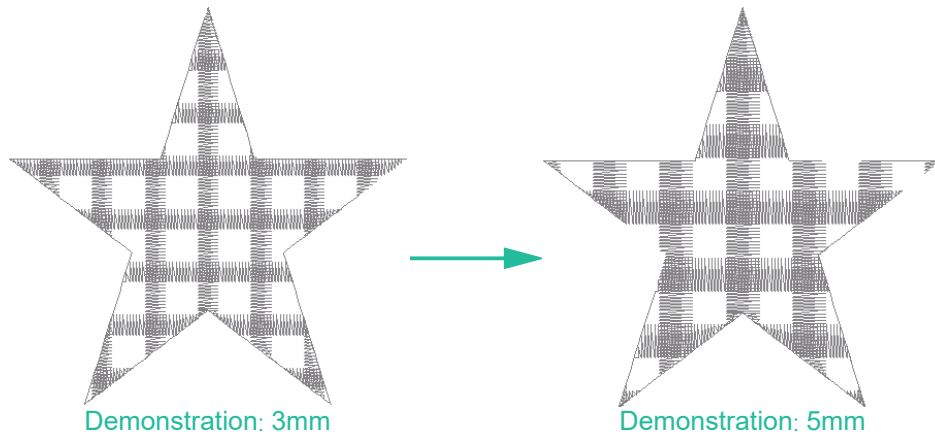

 Spacing

The distance between Zigzag stitches, 5 (default), unit: mm.

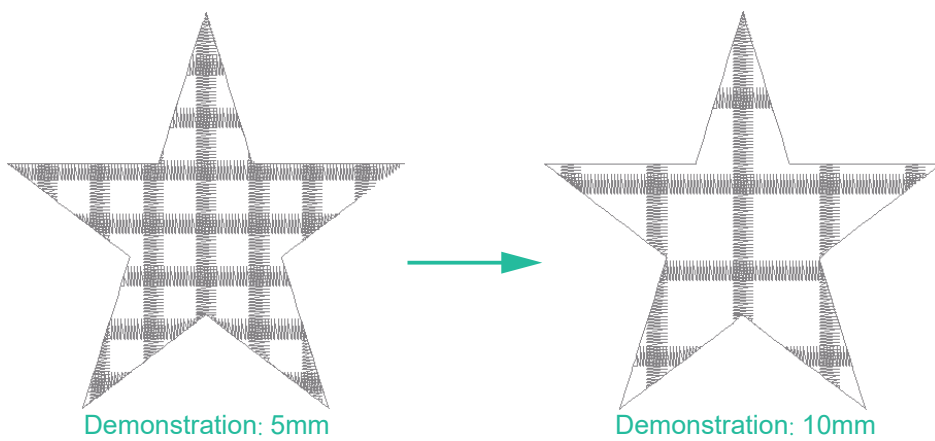

 Horizontal Offset:

Adjust the horizontal axis offset distance, 0 (default), unit: mm.

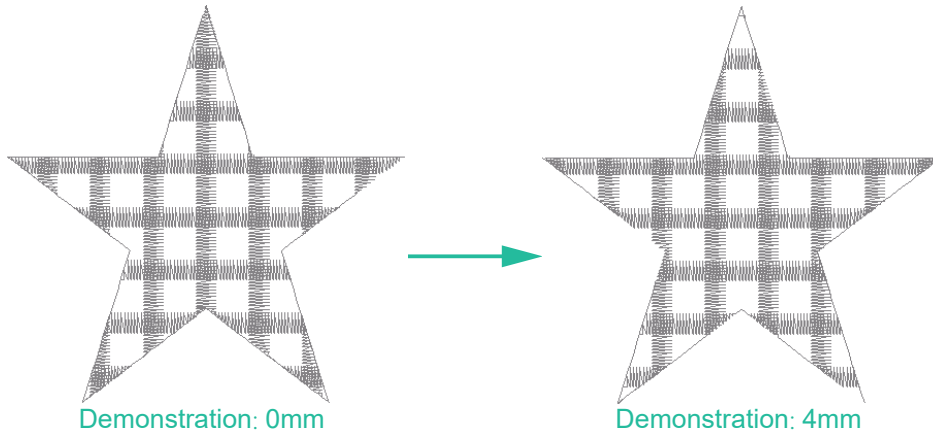

 Vertical Offset:

Adjust the vertical axis offset distance, 0 (default), unit: mm.

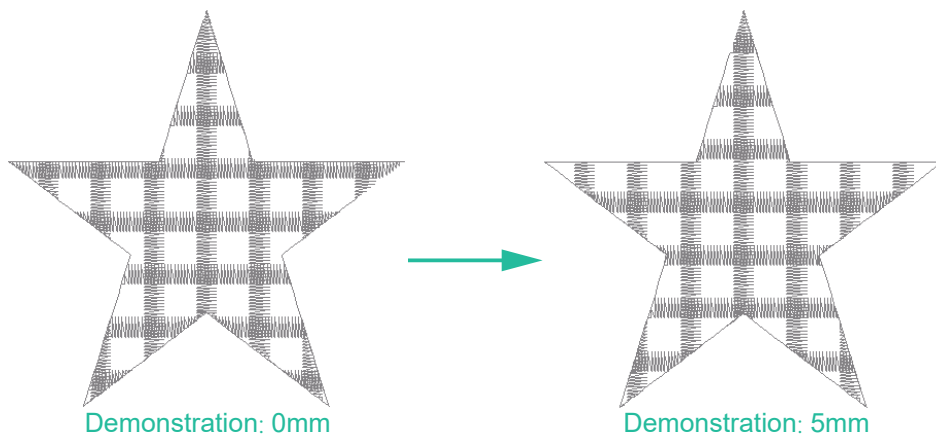

Radial Stitch

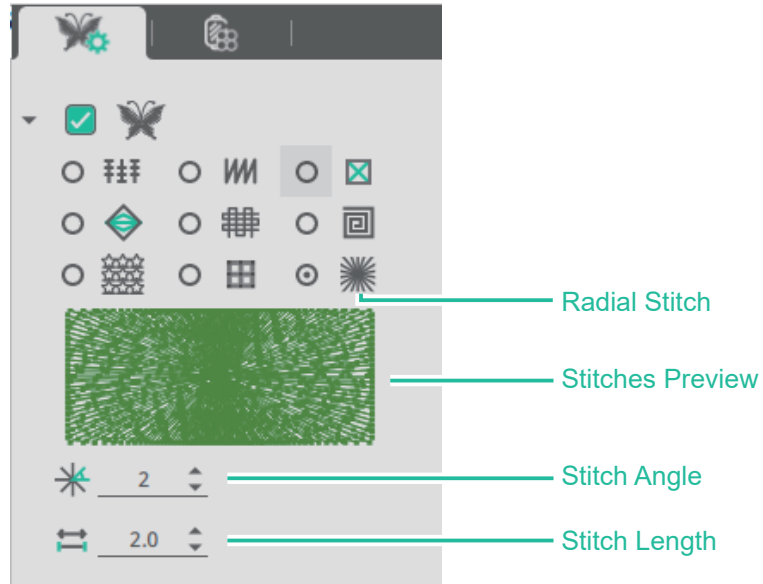

※ The parameters below can be adjusted and set according to personal preference

 Stitch Angle:

Change the stitch angle, 2 (default), unit: degree.

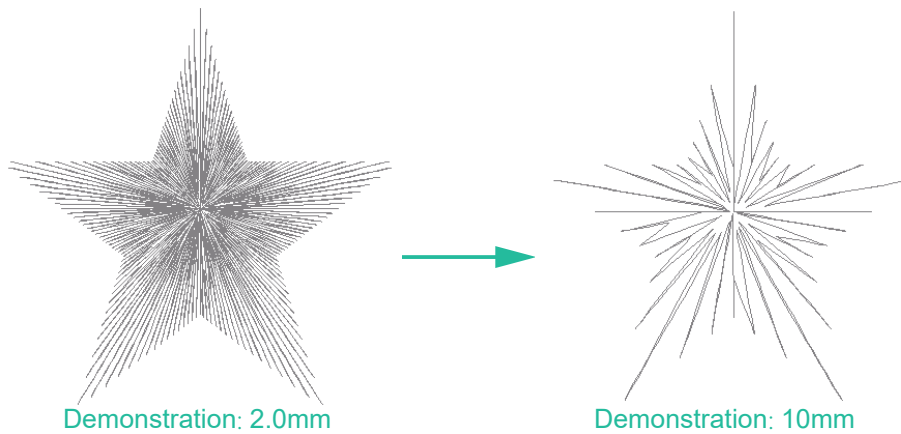

 Stitch Length:

Adjust the distance between two stitches, 2 (default), unit: mm.

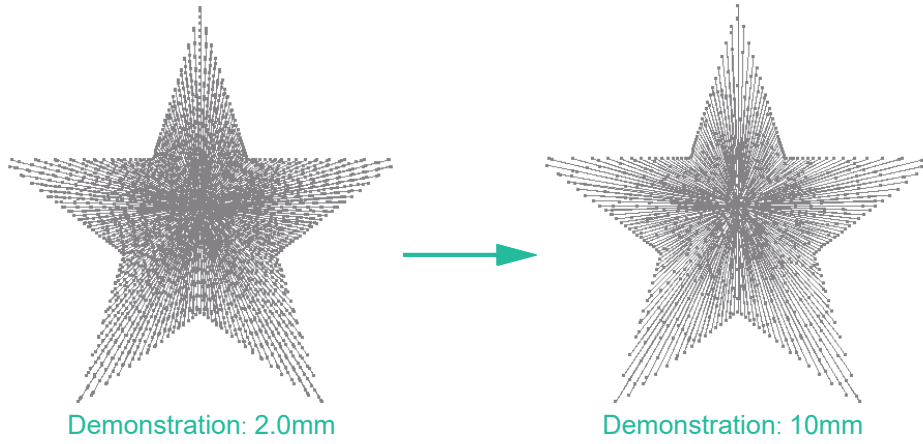

Underlay

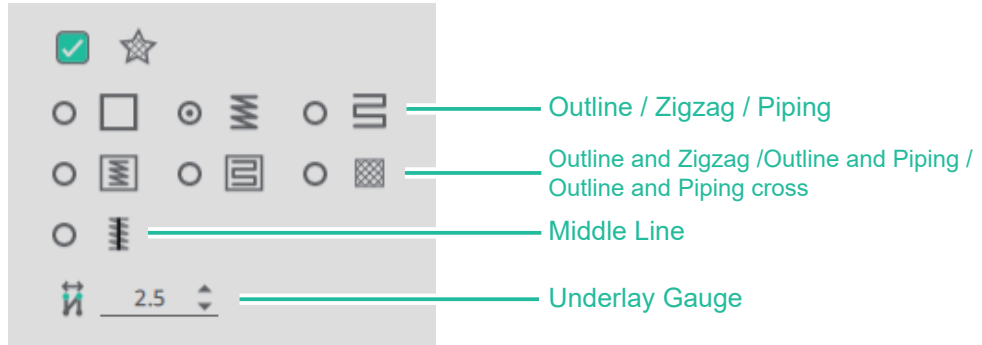

※ The stitches used in some areas can be used with the bottoming function. If there are any function options on the screen, please refer to the following instructions.

Underlay For Outline

Path: <Underlay>

Description:

It will underlay for outline.

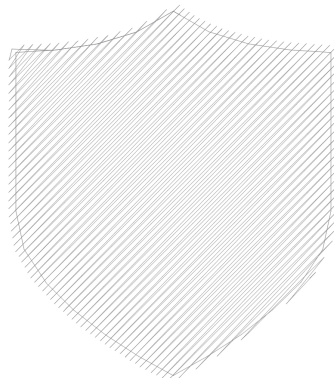



Underlay For Zigzag

Path: <Underlay>

Description:

It will underlay for zigzag (width adjustable)

1. When complex fill stitch, stitches will underlay vertically
2. When satin fill stitch, stitches will underlay horizontally

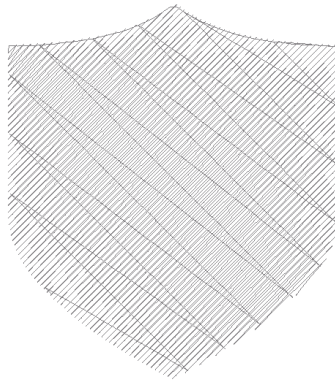

Underlay Gauge:

The distance between two lines, 2.5 (default), unit: mm.

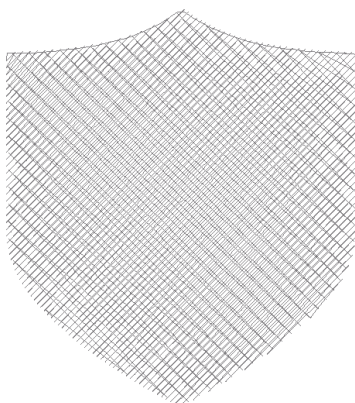

Demonstration: 2.5mm

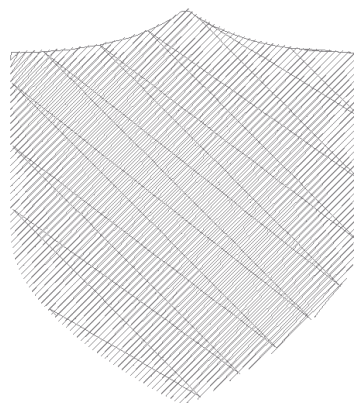

Demonstration: 10mm

Underlay For Piping

Path: <Underlay>

Description:

It will underlay vertically for piping.

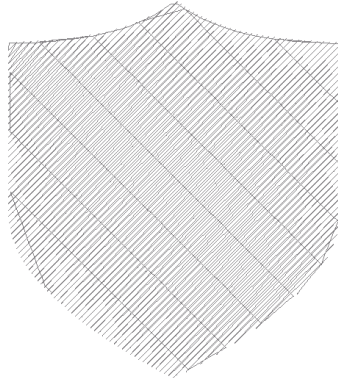

Underlay Gauge:

The distance between two lines, 1.5 (default), unit: mm.

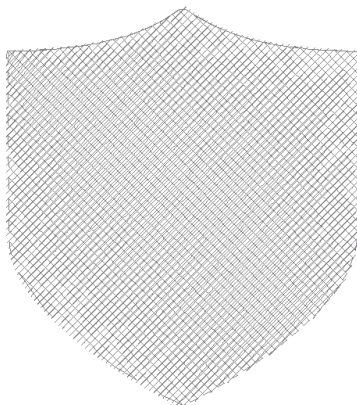

Demonstration: 1.5mm

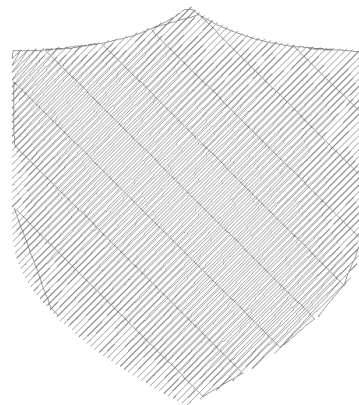

Demonstration: 10mm



Underlay For Outline and Zigzag

Path: <Underlay>

Description:

It will underlay for outline and zigzag (width adjustable).

1. When complex fill stitch, stitches will underlay vertically.
2. When satin fill stitch, stitches will underlay horizontally.

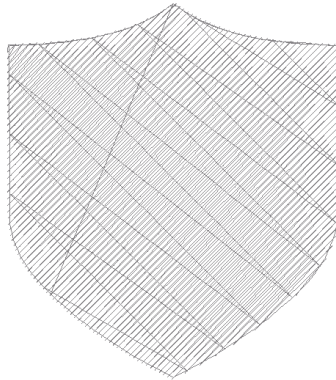

Underlay Gauge:

The distance between two lines, 2.5 (default), unit: mm.

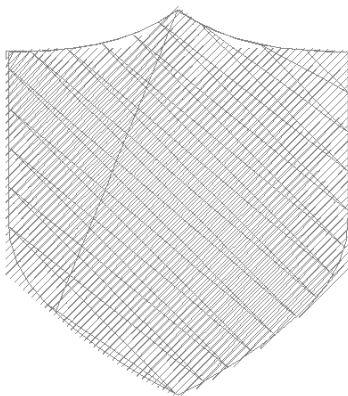

Demonstration: 2.5mm

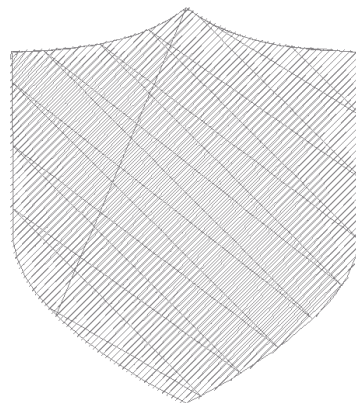

Demonstration: 10mm

Underlay For Outline and Piping

Path: <Underlay>

Description:

It will underlay for outline first and for piping vertically.

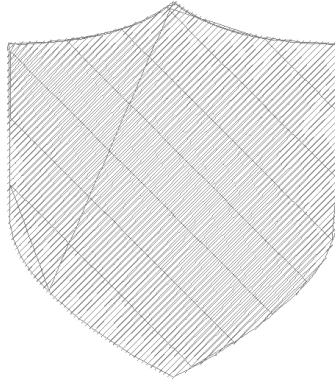

Underlay Gauge:

The distance between two lines, 1.5 (default), unit: mm.

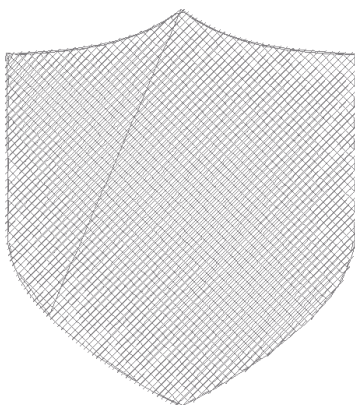

Demonstration: 1.5mm

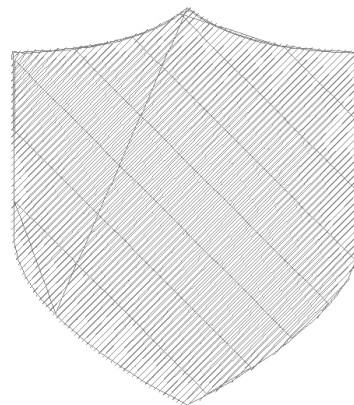

Demonstration: 10mm



Underlay For Outline and Piping cross

Path: <Underlay>

Description:

It will underlay for outline first and then zigzag and piping stitches in 45° and 135°.

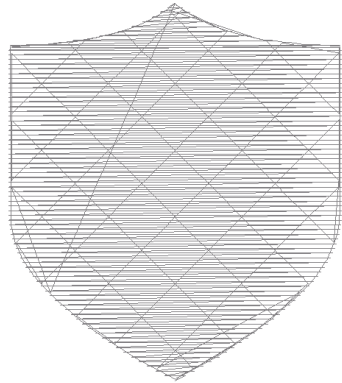

Underlay Gauge:

The distance between two lines, 2.0 (default), unit: mm.

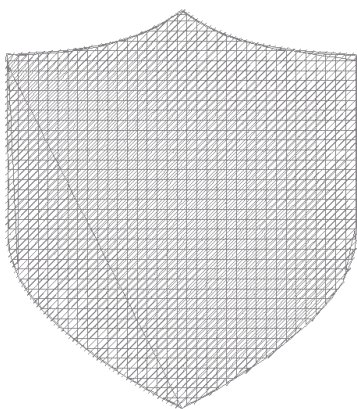

Demonstration: 2.0mm

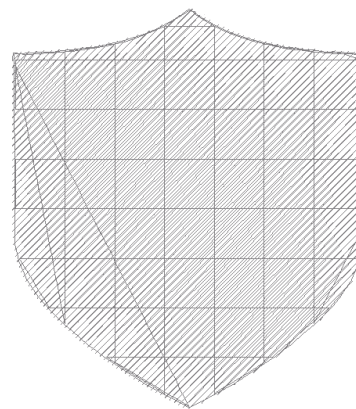

Demonstration: 10mm



Underlay For Middle Line

Path: <Underlay>

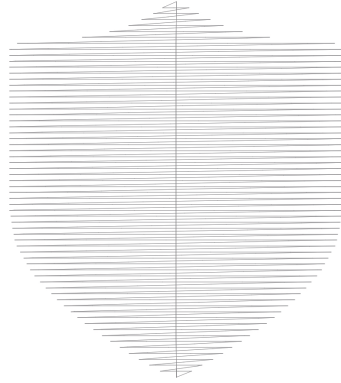

Description:

It will underlay for middle line two to three times.



Line Sew

Steps:

1. Click on the object.
2. The preset contour sewing icon mode is . When the icon is clicked again , it will cancel contour sewing.

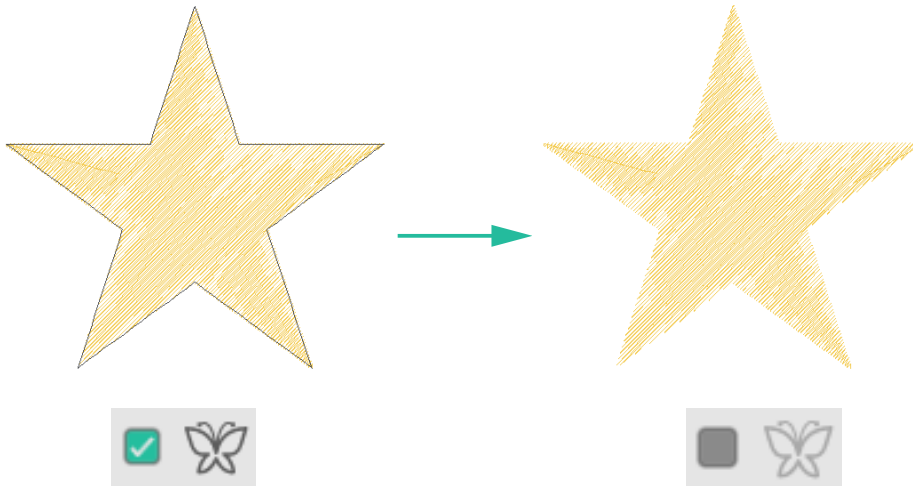

--- Single Outline

The number of round trips for two stitches is once



※ The parameters below can be adjusted and set according to personal preference

 Stitch Length:

Adjust the distance between two stitches, 2.0 (default), unit: mm.



Triple Outline

The number of round trips for two stitches is three times.

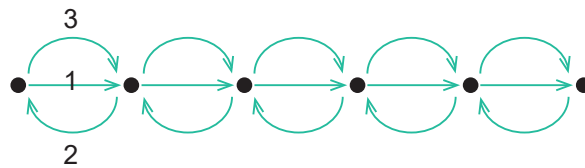

※ The parameters below can be adjusted and set according to personal preference

 **Stitch Length:**

Adjust the distance between two stitches, 2.0 (default), unit: mm.



 **Satin Stitch**

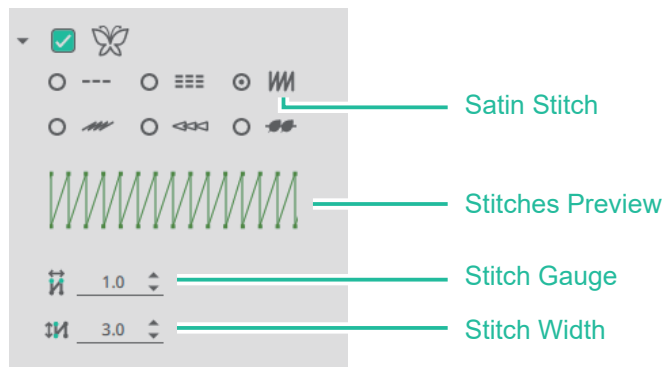

※ The parameters below can be adjusted and set according to personal preference

 Stitch Gauge:

The distance between two lines, 1.0 (default), unit: mm.



Demonstration: 1.0mm

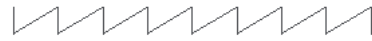

Demonstration: 10mm

 Stitch Width:

Stitch Width, 3.0 (default), unit: mm.



Demonstration: 3.0mm

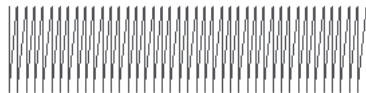

Demonstration: 10mm



Stem stitch

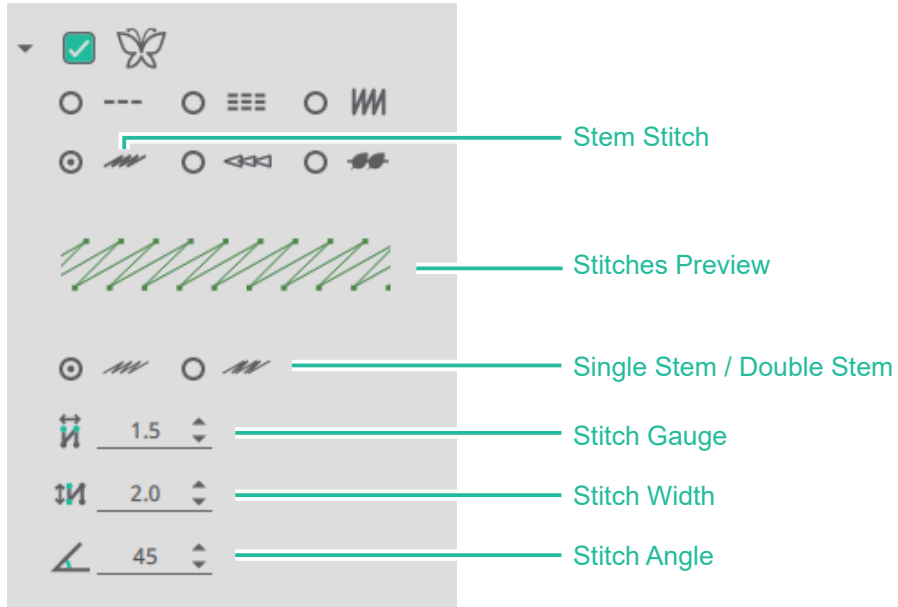

Stem stitch distinguish between the following two embroidery methods:



Single Stem



Double Stem

※ The parameters below can be adjusted and set according to personal preference

 Stitch Gauge:

The distance between two lines, 1.5 (default), unit: mm.



Demonstration: 1.5mm



Demonstration: 4.5mm

 Stitch Width:

Stitch Width, 2.0 (default), unit: mm.



Demonstration: 2.0mm



Demonstration: 3mm

 Stitch Angle:

Change the direction of the stitching method, 45 (default), unit: degree.



Demonstration angle: 45°



Demonstration angle: 100°

Chain Stitch

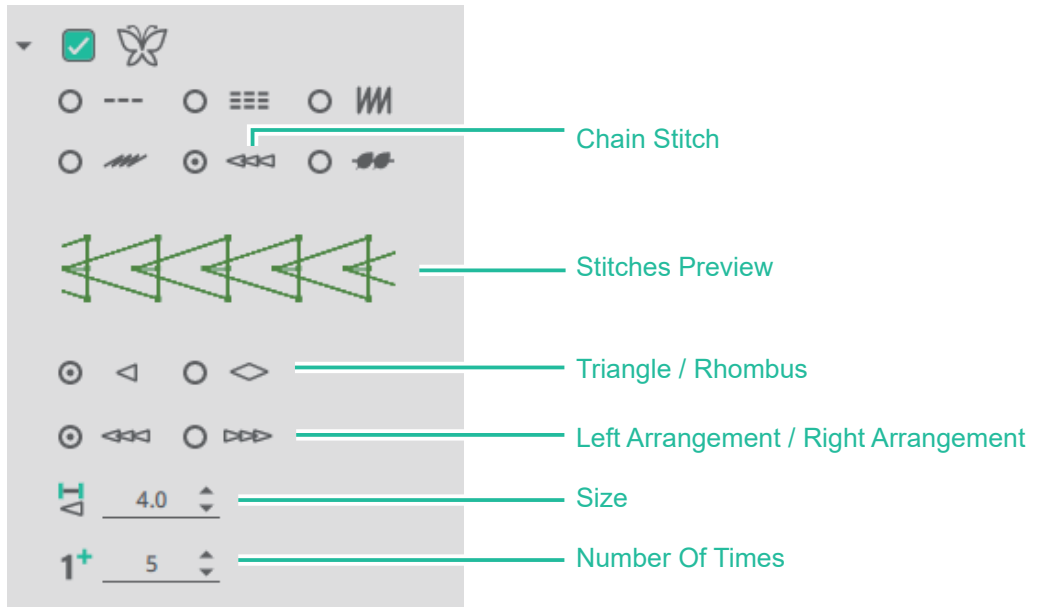

Chain Stitch distinguish between the following two embroidery methods:



Triangle



Rhombus

Arrangement:

Left arrangement - start on the left and end on the right

Right arrangement- start on the right and end on the left



Left Arrangement



Right Arrangement

※ The parameters below can be adjusted and set according to personal preference

 Size:

Size, 4.0 (default), unit: mm.



Demonstration: 4.0mm



Demonstration: 5.0mm

1+ Number Of Times:

Number of times, 5 (default), unit: times.

Motif stitch

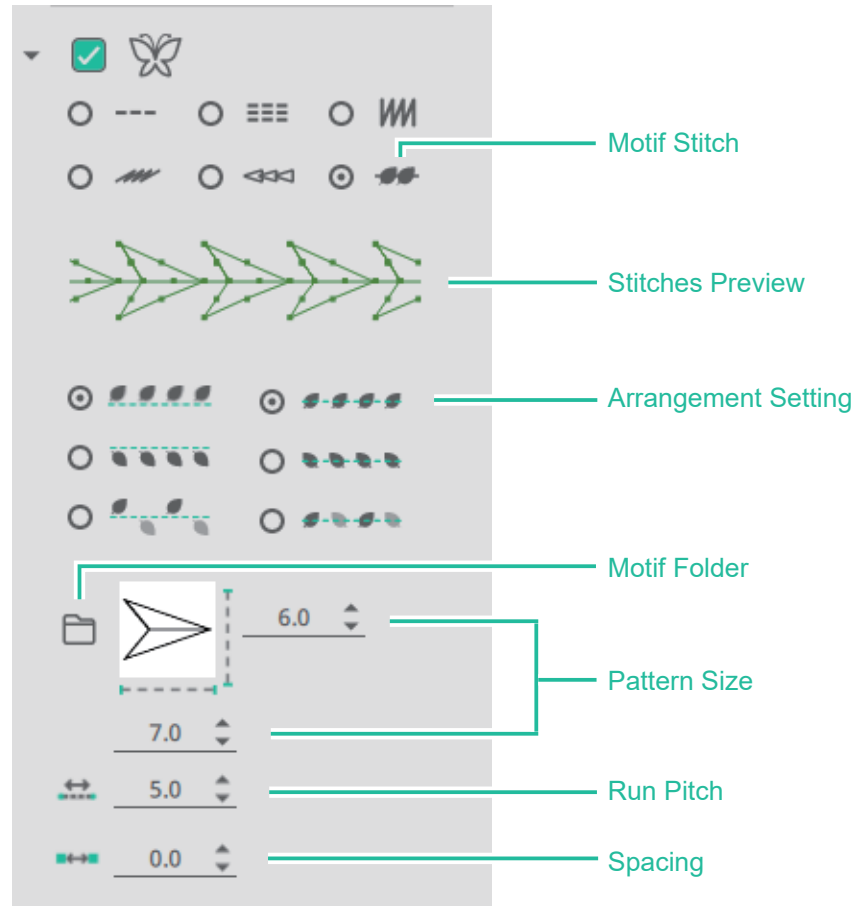

Motif stitch distinguish between the following six arrangement setting:

Horizontal arrangement(default): The Motif pattern embroidery are arranged upward along the horizontal axis.



Horizontal mirror : Arrange the Motif pattern embroidery downward along the horizontal axis.



Horizontal stagger : The Motif pattern embroidery are arranged one up and one down along the horizontal axis.

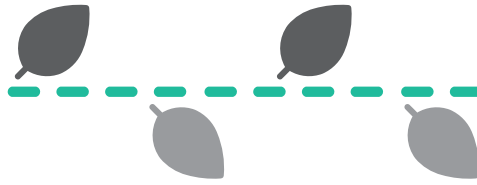

Vertical arrangement (default): The Motif pattern embroidery are arranged to the right along the vertical axis.



Vertical mirror : Arrange the Motif pattern embroidery to the left along the vertical axis.



Vertical stagger : The Motif pattern embroidery are arranged alternately on the right and left along the vertical axis.



📁 Motif Folder:

Pattern embroidery pattern list.



※ The parameters below can be adjusted and set according to personal preference
Pattern size: Set the height size, width size, unit: mm.

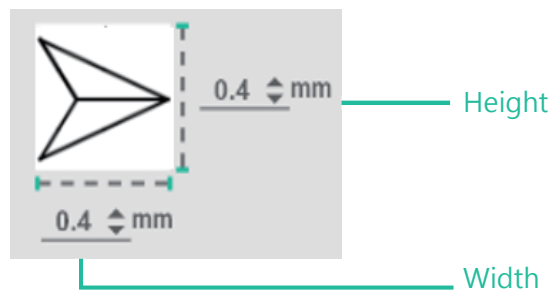

※ The following parameters can be used to adjust the number of needle points according to personal preference.

↔ Run Pitch Setting:

Stitch length judgment value setting for pattern embroidery, 5.0mm (default), unit: mm

Set the stitch distance for a pattern embroidery to 2.0mm. If the stitch distance in a single pattern is greater than 2.0mm, the needle drop point will increase.

Not exceeding the stitch distance setting of 2.0mm, will not increase needle points

Exceeding the stitch distance setting of 2.0mm, will increase needle points (see in the arrow)

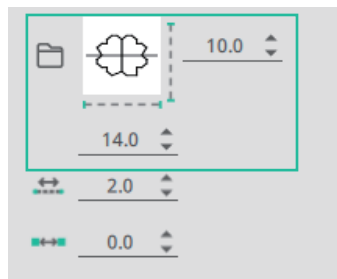
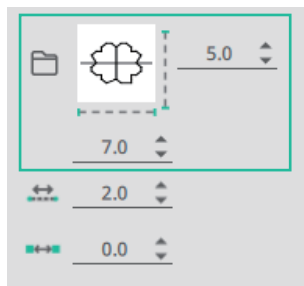
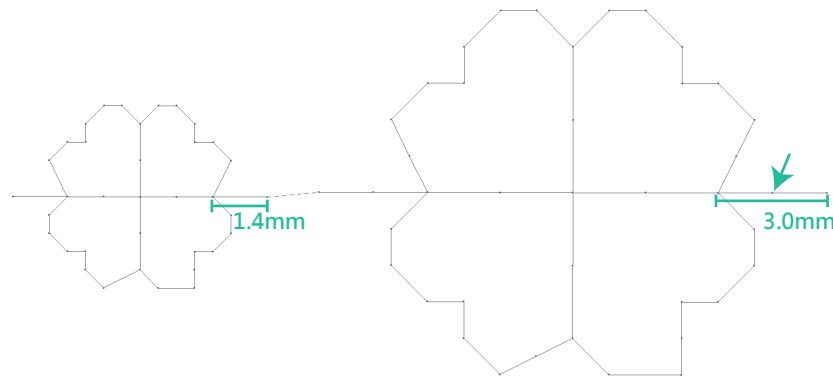

↔ Spacing:

Setting the length between Motif pattern, 0.0 (default), unit: mm.



Demonstration: 0.0mm



Demonstration: 3.0mm

● Text stitches setting



Stitch Effect

Path: <Stitch Effect>

Description:

It is divided into area sewing and contour sewing setting. When the function icon is pressed, the stitch selection can be made for the selected vector pattern object, and the embroidery parameters can be set, including angle, thread pitch, stitch length, Staggered way... etc.



Region Sew

Steps:

1. Click on the object.
2. The preset sewing area mode is . When the icon is clicked again , it will cancel the sewing area.

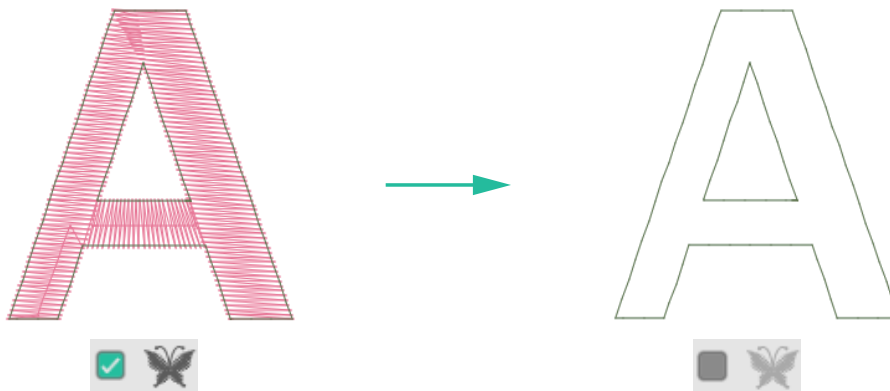

3. After clicking the contour sewing icon, the parameters below can be adjusted and set according to personal preference.

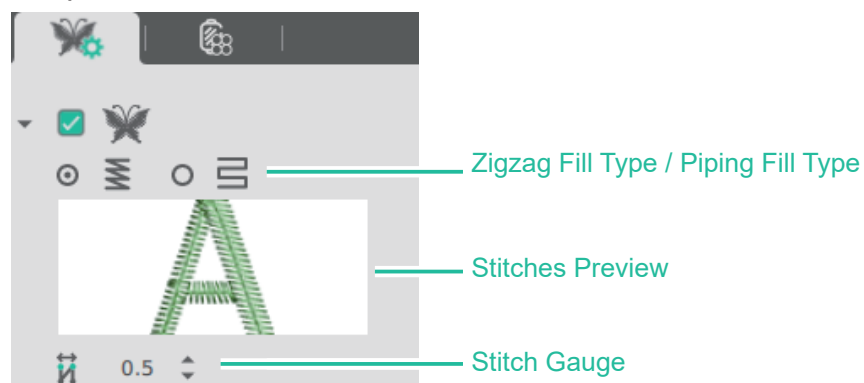

※  Stitch Gauge:

The distance between two lines, 0.5 (default), unit: mm.

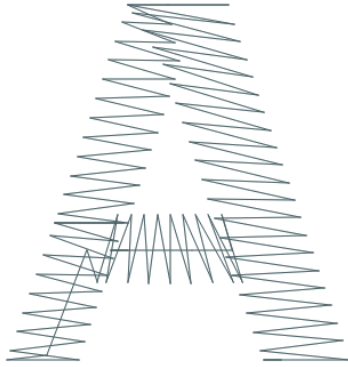

Demonstration Stitch Gauge:
0.5mm

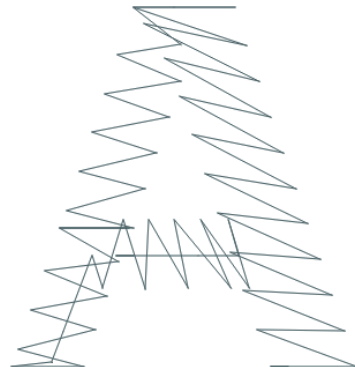

Demonstration Stitch Gauge:
1.0mm



Underlay



Underlay for outline

Path: <Underlay>

Description:

It will underlay for outline.



Underlay for zigzag

Path: <Underlay>

Description:

It will underlay for zigzag (width adjustable).

※ Stitch Gauge: 3.0 (default), unit: mm.

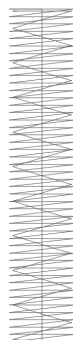



Underlay for outline and zigzag

Path: <Underlay>

Description:

It will underlay for outline and zigzag (width adjustable).

1. When complex fill stitch, stitches will underlay vertically.
2. When satin fill stitch, stitches will underlay horizontally.

※ Underlay for zigzag

Stitch Gauge: 3.0 (default), unit: mm.



Underlay for middle line

Path: <Underlay>



Description:

It will underlay for middle line two to three times.



Line Sew

Steps:

1. Click on the object.
2. The preset of the contour sewing is in inactive status . When the icon is clicked will appear , clicked again will cancel contour sewing.

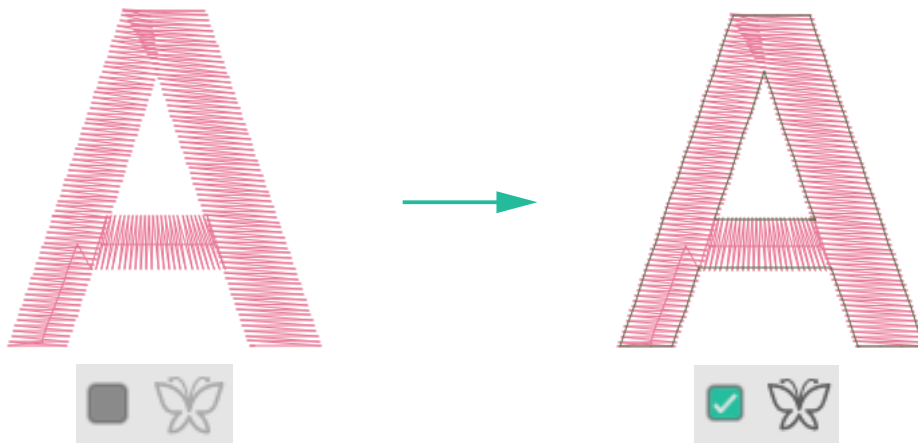

3. After clicking the contour sewing icon, the parameters below can be adjusted and set according to personal preference.

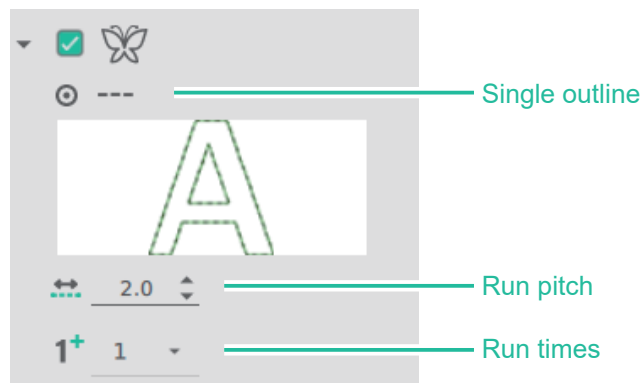

※  Run Pitch:

Adjust the distance between two stitches, 0.5 (preset), unit: mm.

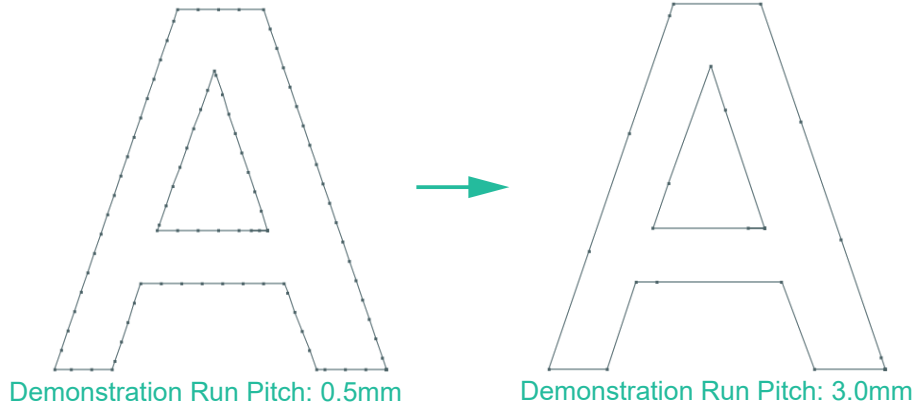

※  Run times:

The number of embroidery of the outer frame line, you can choose 1, 3, 5 times.

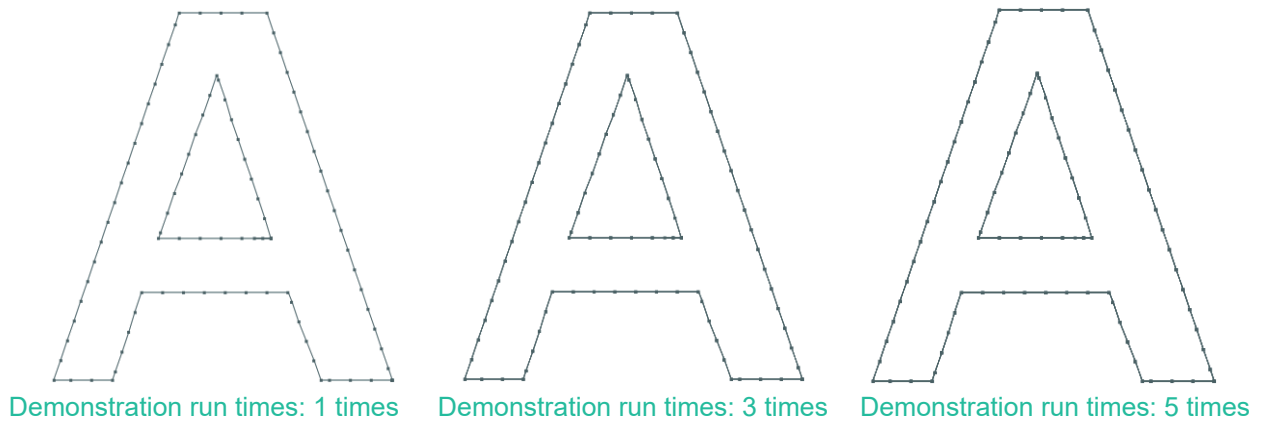



Convert To Embroidery Object

Path: <Convert To Embroidery Object >

Description:

Convert vector object into stitch object and after converted, the stitch object will have dotted line to differentiate.

Steps:

Click the objects you want to convert, and click <Convert To Embroidery Object> from the menu.

※ In Text Manager, Monogram mode, Paint mode, the files are generated in vector format.

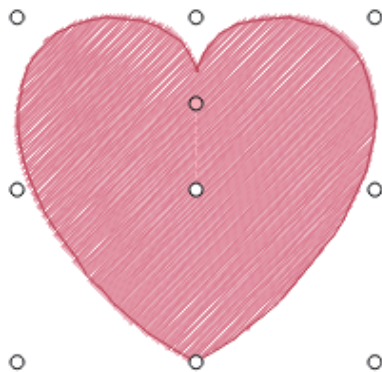

Vector Object

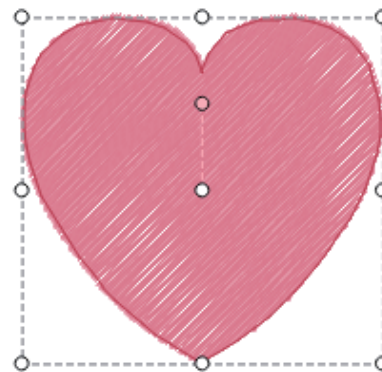

Embroidery Object

Embroidery Preview and Setting



Thread Table

Path: <Thread Table>

Description:

The user can change the selected thread color brand and change the embroidery color; for the selected object, click the left mouse button to fill the color in the area, and click the right mouse button to fill the outline color. The area and color will appear on the color wheel from the outline of the butterfly symbol.

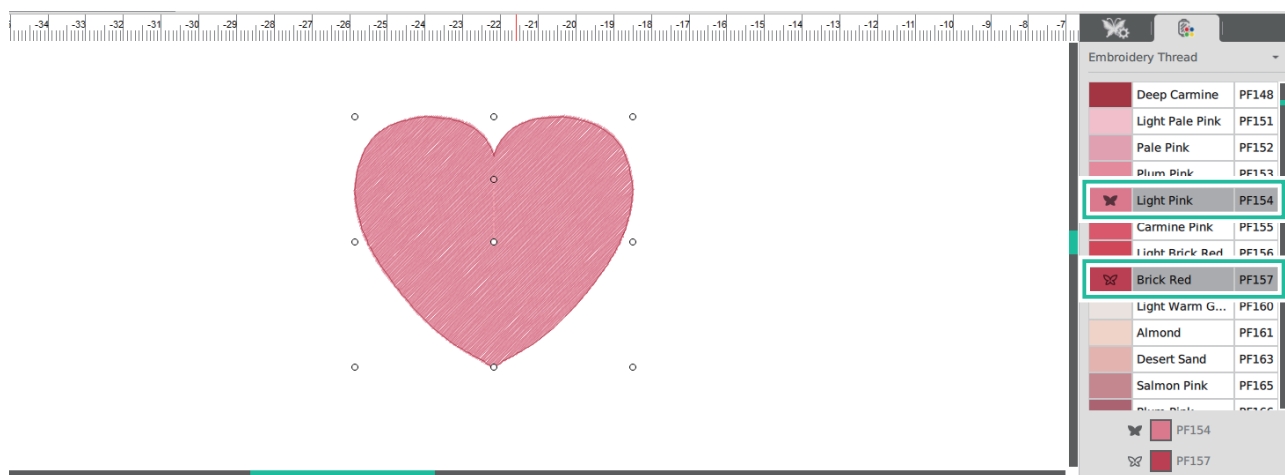

※ On the stitch file, click the left mouse button or the right button to fill in color directly and the butterfly symbol of the area and outline will appear on the color wheel at the same time.

Embroidery Thread		
	Light Pale Pink	PF151
	Pale Pink	PF152
	Plum Pink	PF153
	Light Pink	PF154
	Carmine Pink	PF155
	Light Brick Red	PF156

Objects drawn using the "Drawing Module" tool, including line satin, cache patterns, etc., will be automatically brought the default color (area-gray/line-dark gray), when the color of the area and outline on the color wheel is reset, the object drawn again will produce color with the reset color.

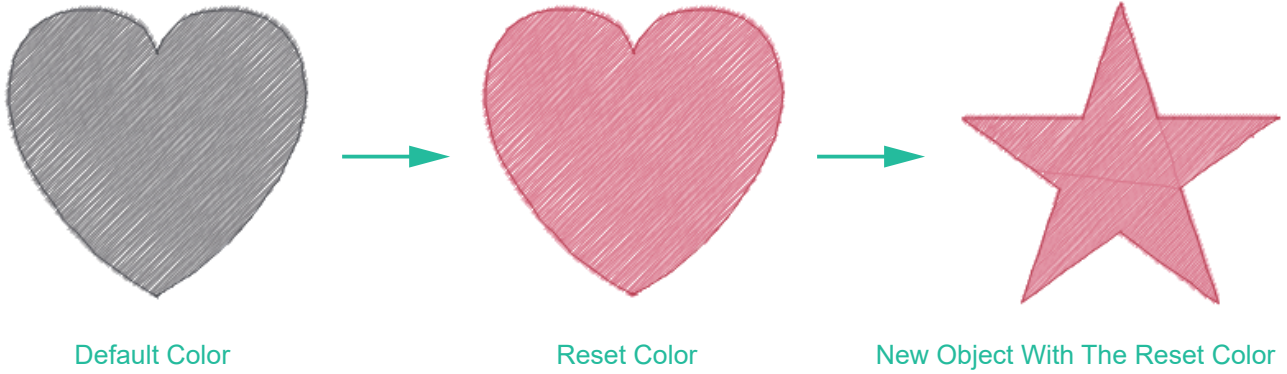

The text objects drawn by the tools of "Text Module" and "Combined Character Module", the default color is dark gray color. After the text color is reset, the new text design will continue to maintain the default color dark gray.

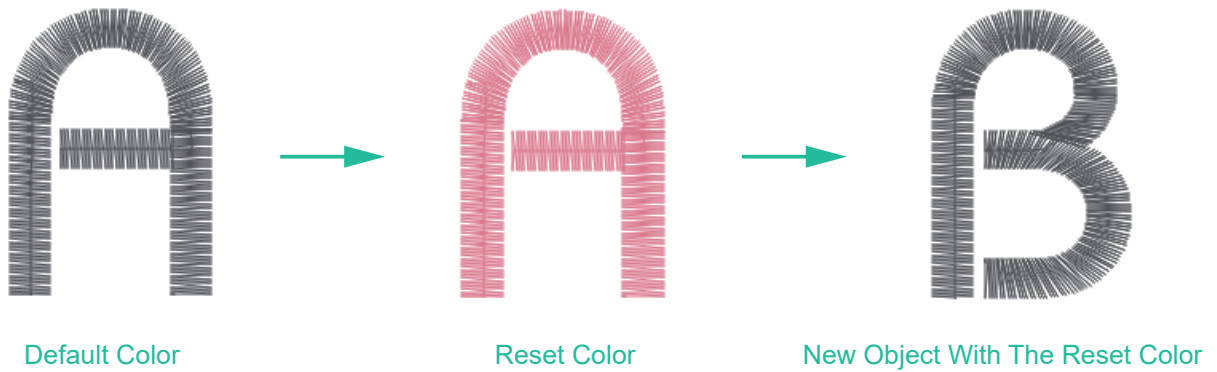

The selected single object will bring out the color information used by the object in the color wheel information. If multiple objects or group objects are selected, the used color information will not be brought out.

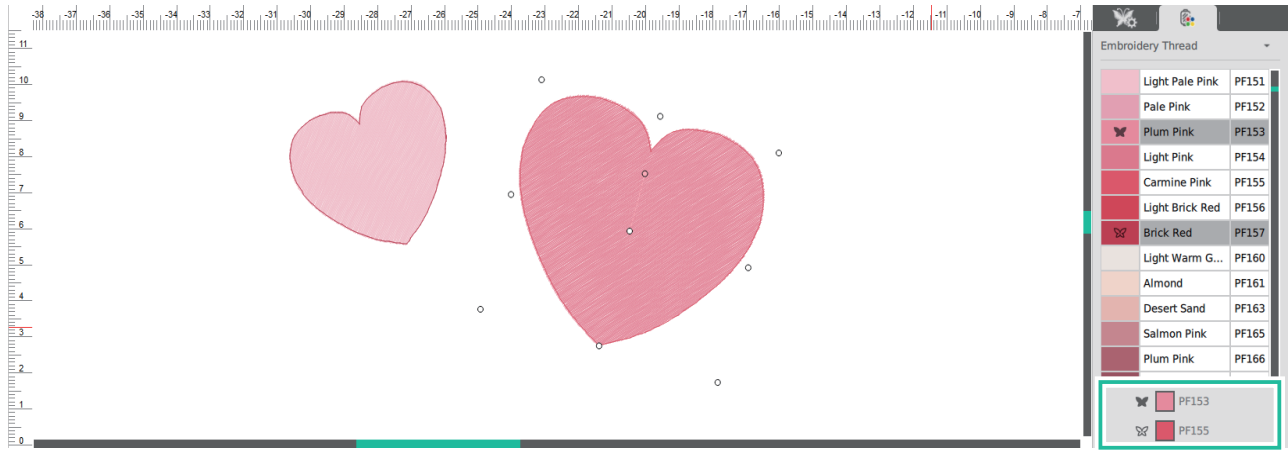

Single Object

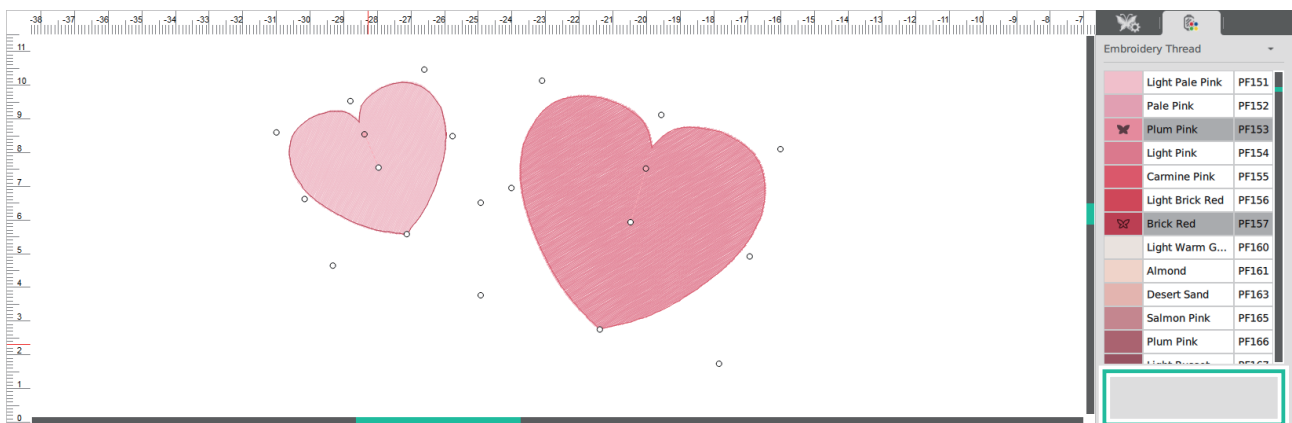

Multiple Objects

● Select Thread Color



Select Thread Color

Path: <Select Thread Color>

Description:

Sort according to the color of each block, add and modify colors according to the thread colors of each brand.

Steps:

1. Click <Select Thread Color>
 2. In the dialog box, select the section you wish to change and import the selected thread color manufacturer's designated color, or you can directly enter the thread color number or color name in the color number box to specify the desired color.
- ※ After selecting the color in the thread list, you can use the left mouse button on the top of the color to quickly click twice to quickly import the color.

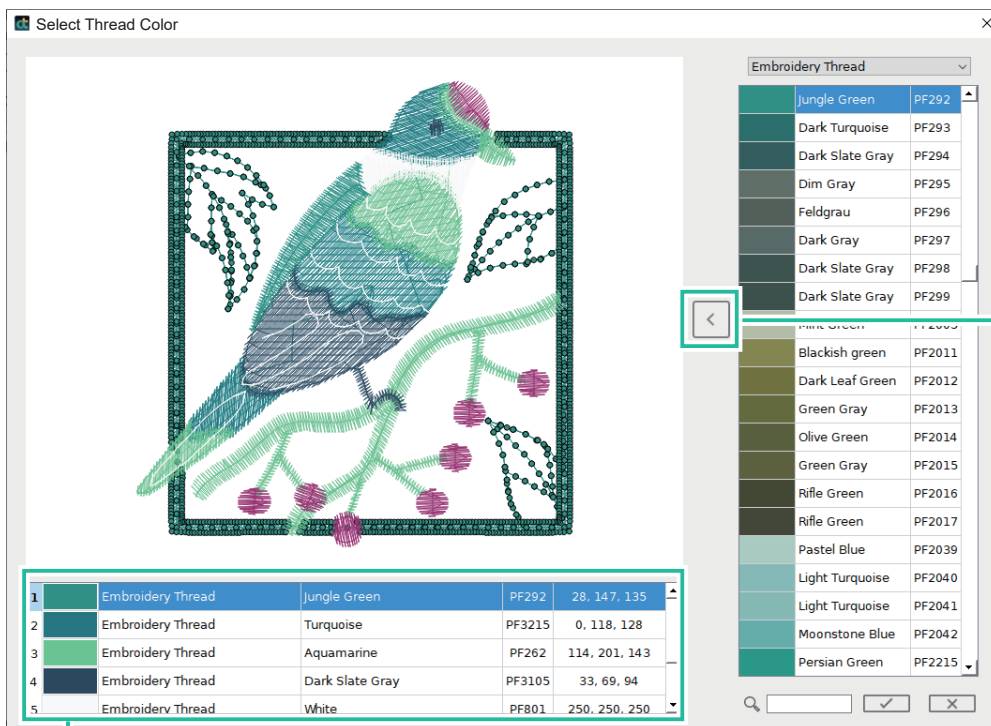

Color Information



Set User's Thread Color

Path: <Set User's Thread Color>

Description:

Can create own labels for frequently used thread colors, add and modify colors.

Steps:

1. Click <Set User's Thread Color>, a window (Set User's Thread Color) appears, click <Add New Users Thread Brand>, a window (New User Brand) appears, enter the name according to personal needs, and finally click to create ✓ .
2. Customize the name of the brand: select the thread color required by each brand, import it into the custom brand, and also edit and change the name, thread name, thread color number or delete it, and add customization R, G, B numerical value color or adjust the R, G, B numerical value to set the desired color.

Add New Users Thread Brand

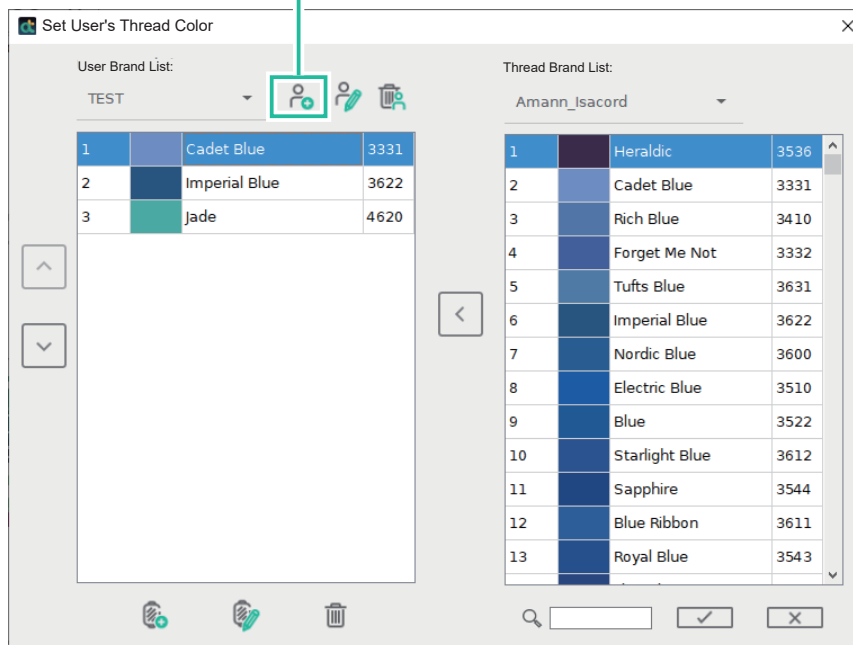

Set Embroidery Sequence

Path: <Set Embroidery Sequence>

Description:

Set the embroidery order of each stitch object, and display continuous blocks of the same color in the same color group.

Steps:

1. Click <Set Embroidery Sequence> and a window (Set Embroidery Sequence) will appear.
2. To enlarge the pattern to make it clearer, check <Enlarge> to fill the frame with stitch objects.
3. To change the sewing order of a color, select the color frame you want to move, and then drag the frame to the target position or use the left and right buttons to adjust.

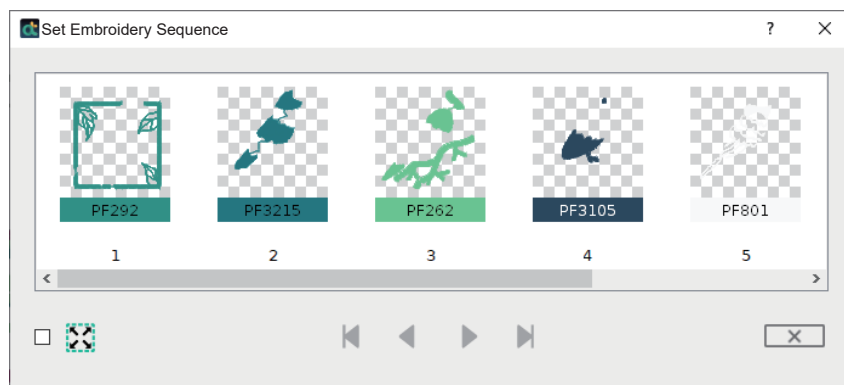

Run Stitches

Path: <Run Stitches>

Description:

Stitch simulator function On/Off.

For the selected one or more embroidery patterns that have generated stitch paths, perform stitch embroidery simulator on the computer screen.

Steps: Click <Run Stitches> directly from the toolbar.

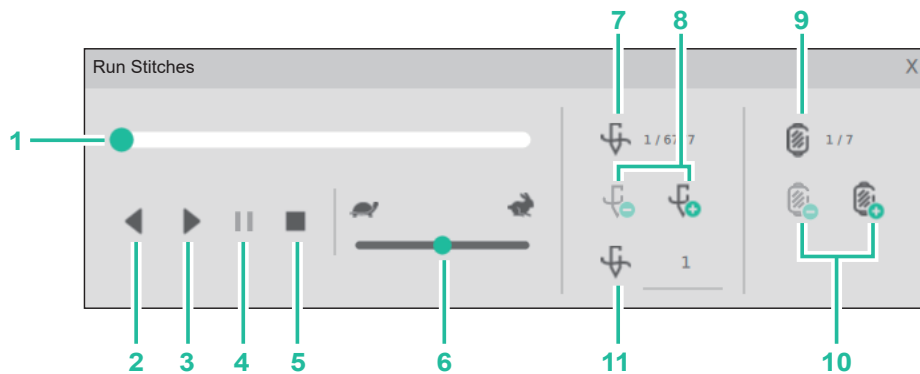

1. **Embroidery position:** The slider shows the current progress of the simulator, and you can also move the slider to change the simulator progress.
2. **Rewind:** start stitch simulator and simulate stitch forward.
3. **Play:** start stitch simulator, and simulate stitches in backward.
4. **Pause:** When the stitch simulator is on forward or backward, press this key to pause.
5. **Stop:** stop the simulator, and the simulator position will return to the first stitch at the beginning.
6. **Speed:** drag the slider to adjust the stitch speed.
7. **Display the current number of stitches / Total number of stitches.**
8. **Previous stitch:** One stitch forward.
Next stitch: One stitch backward.
9. **Thread color layer:** Current thread color / Number of all thread colors.
10. **Previous thread:** return to the beginning of the previous thread color stitch.
Next thread: return to the beginning of the next thread color stitch.
11. **Current stitch number:** Can input specified stitch numbers.

Shortcut key (Stitch simulator) :

1. "ESC key" is the exit mode. ESC (Windows system)/ ESC (OS system)
2. "+" to the next stitch, press "-" to go back to the previous stitch.
"+/-"(Windows system) / " ⬆ +/-"(OS system)
3. Press the "Ctrl" button with the mouse wheel or the "Ctrl" button with the "+/-" button to zoom in/out the window. Ctrl (Windows system) / Command (OS system)
4. It can be used with the blank key to pan the screen.

Show/Hidden Needle Point

Path: <Show/Hidden Needle Point>

Description: To display each needle point in embroidering.

Steps:

Directly click <Show/Hidden Needle Point> from the toolbar to show or hide the needle point.

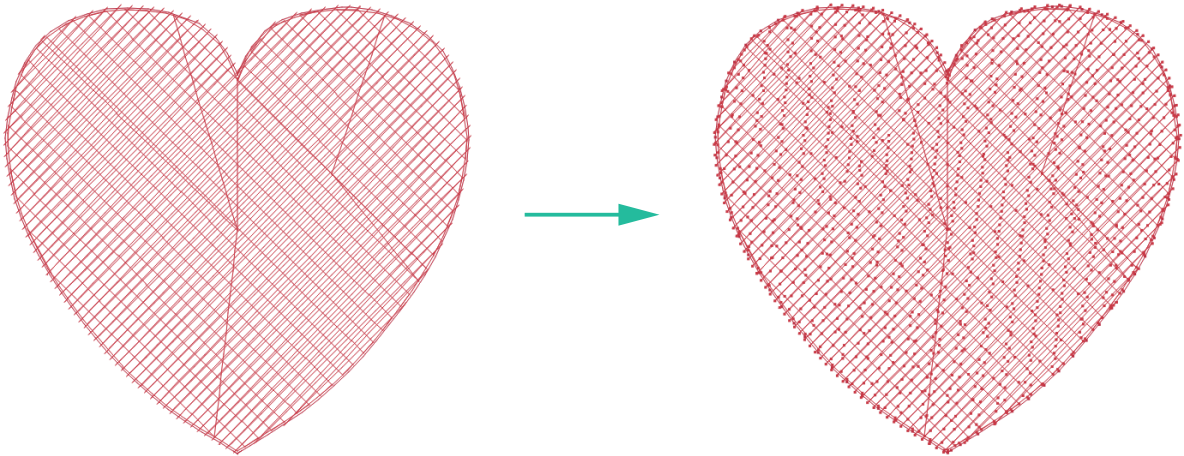

3D Simulate

Path: <3D Simulate>

Description: The stitch lines are displayed in 3D simulation mode.

Steps:

Directly click on <3D Simulate> from the toolbar to preview the finished product.

Shortcut key:

In 3D simulation, press "ESC" to exit mode. ESC (Windows system) / ESC (OS system)

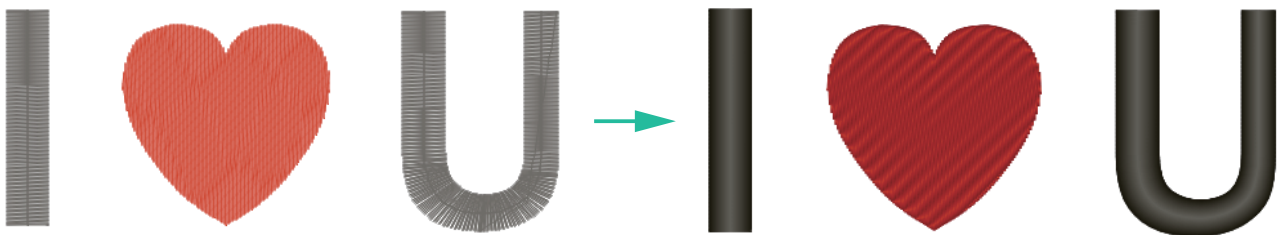

Work Area Settings

Show / Hidden Grid

Path: <Show/Hidden Grid>

Description: Toggle On/Off the display of the grid.

Steps:

Directly click <Show/Hidden Grid> from the toolbar to show or hide the grid (Grid).

Show / Hidden Axis

Path: <Show / Hidden Axis>

Description: Show/Hide the center mark line (Axis).

Steps:

Directly click <Show / Hidden Axis> from the toolbar to show or hide the center mark line.

Show/Hidden Hoop

Path: <Show / Hidden Hoop>

Description: Toggle On/Off the display of the hoop frame on screen.

Steps:

Directly click on <Show / Hidden Hoop> from the toolbar to show or hide the embroidery frame.

100 X 100mm	▼
40 X 40mm	
50 X 70mm	
• 100 X 100mm	
110 X 170mm	
120 X 180mm	
160 X 260mm	

Change Hoop Size

Description:

Provide embroidery hoops of different sizes for users to choose. The default hoop size is 100*100mm.

There are six kinds of embroidery hoop sizes: Hoop- 40×40mm, Hoop 50×70mm, Hoop-100×100mm, Hoop-110×170mm, Hoop-120×180mm, Hoop-160×260mm.

Steps: Click on the menu toolbar and select the appropriate embroidery hoop size.



Fabric

Path: <Fabric>

Description: Choose the fabric material and color you want to match.

Steps:

Directly click on <Fabric> from the toolbar, select the fabric and color, and the background color in the editing area will be switched to the selected fabric and color. Press OK to return to the main screen, and the selected color will be displayed in the editing area. The texture of the cloth will be presented in the 3D simulation function mode.

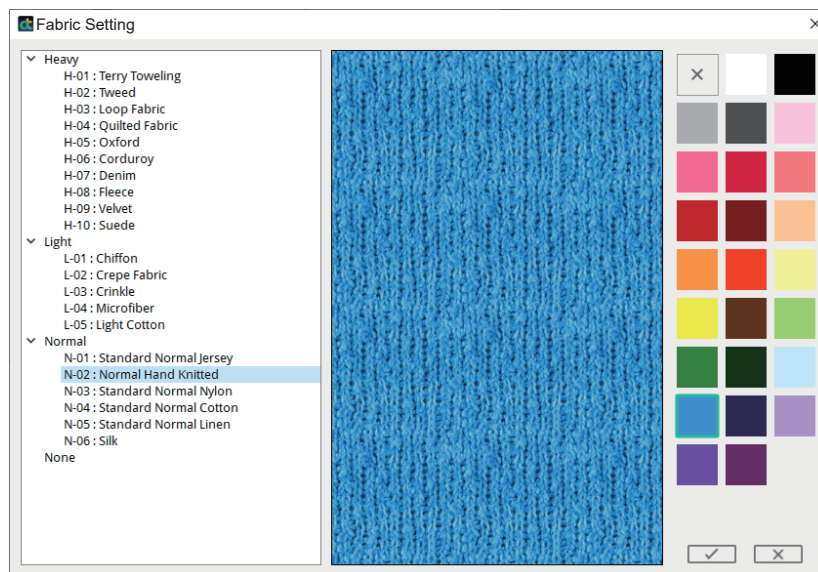

Instruction Manual

Path: <Instruction Manual>

Description: To view the digital version of Instruction Manual.

Steps :

1. Click <Instruction Manual> from the menu.
2. To view the instruction manual in PDF format with Adobe® Reader®.
3. If your computer doesn't have Adobe® Reader® software, download and install it from Adobe Systems Incorporated website (<http://www.adobe.com.tw/>).

Account Functions

Account Functions

Path: <Account Functions>

Description: Account functions

Steps:

1. After first installation, register the user account and password to log in or close the window to skip this step.



- ※ APP account can also log in into "Artist Toolkit" embroidery software, no need to register new account.
- ※ During account registration, you will receive an authentication through your mailbox.

2. The created account can be deleted, log out of account, change password and manage personal information.

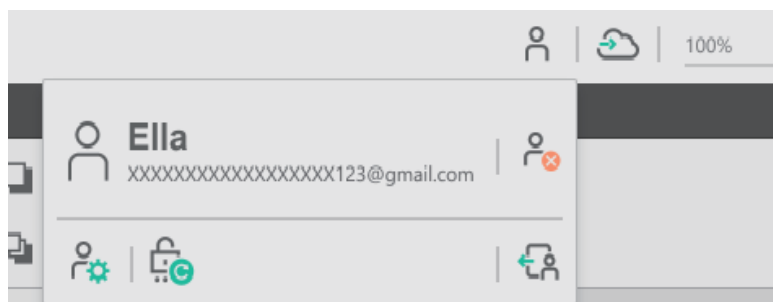

Upload Embroidery File To Cloud

Path: <Upload Embroidery File To Cloud>

Description: File transfer to cloud

Steps:

Click on <Upload Embroidery File To Cloud>  ; the file will be transferred to the cloud, and a successful message will appear.

- ※ After logging in to the account, there must be an image file in the file before the file can be sent to the cloud.
- ※ Only one file can be placed in the cloud space and repeating upload files will overwrite the old file.

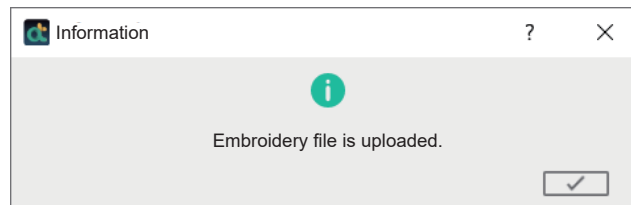

Online Tutorial and Software Version

Tutorial

Path: <Tutorial>

Description: To view the tutorial videos online.

Steps: Click <Tutorial> from the menu.

About

Path: <About>

Description:

Check the copyright information and the version of software your device is running.

Steps: Click <About> from the menu.

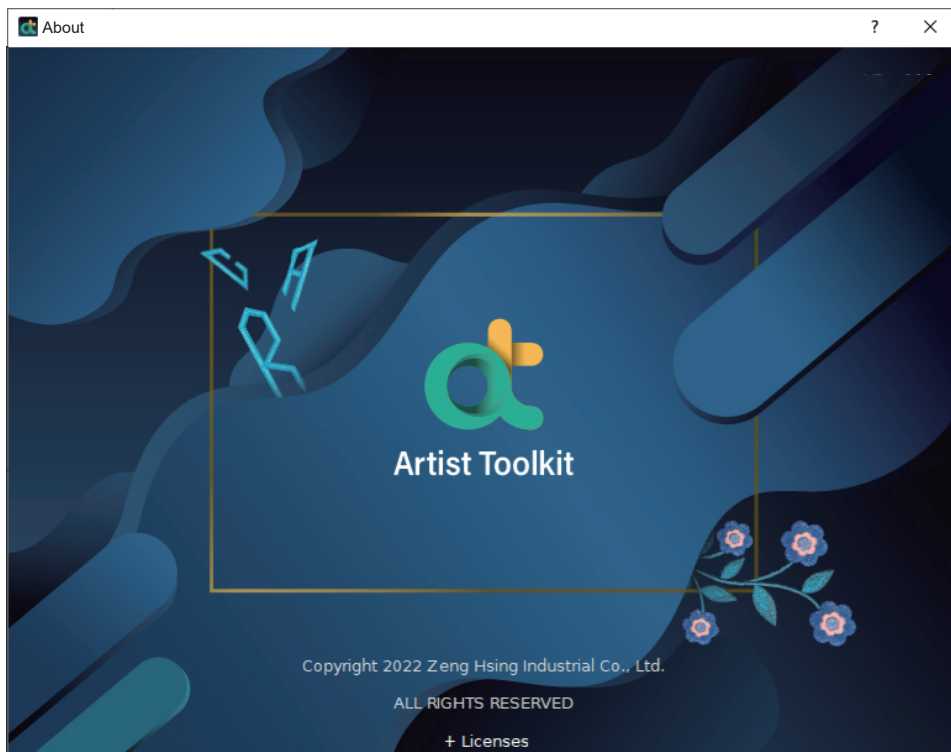

Check Update

Check Update

Path: <Check Update>

Description: Check on the software updates.

Steps:

1. Click <Software Update> from the menu. The software will determine the update automatically.
2. If the latest version is available to upgrade, the software will show the message:
Click <Yes> to download and upgrade the software, after the update is complete, it will restart the software.
Click <No> to skip the upgrade and enter the software.

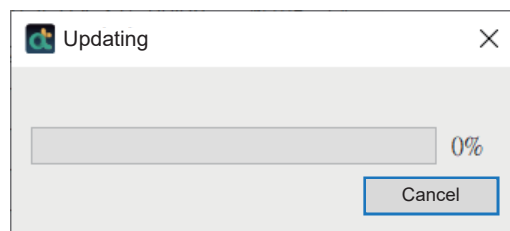
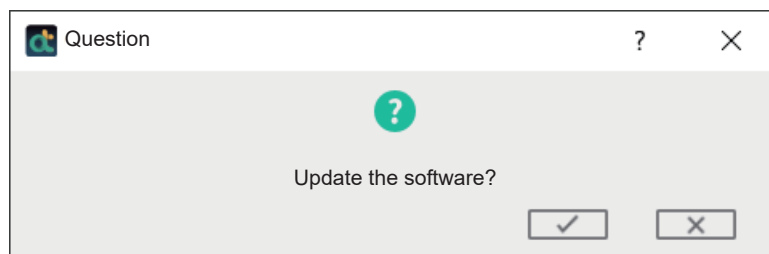

Information

Path: <Information>



Description:



To view the current information of the embroidery design file which includes the file name, size, number of stitches, number of colors and color sequence.



Steps: Click <Information> from the menu.







Information ? X

 Design1  1.1.61

 8606  0

 2  3

 79.0 mm  66.6 mm

1		Ash Orange	PF711
2		Hazel	PF713
3		Red Brown	PF719

Mode Functions

Edit Mode

● View The Patterns In The Preview All Window



Preview All

Path: <Preview All>

Description: View the overall layout of the workspace.

Steps: Click <Preview All> from the menu.

Shortcut key:

Preview all screen mode, press "ESC" to exit.

("ESC" in Windows and OS systems).



Normal / Full Screen

Path: <Normal / Full Screen>

Description: Display the program in a full screen.

Steps: Click <Full Screen> from the menu.

Shortcut key:

Press "F11" to display in a full screen, press "ESC" or "F11" to exit.

("ESC/F11" in Windows systems).



Zoom Object

Path: <Zoom Object>

Description:

Zoom in and view the selected object in the maximum level within the workspace.

Steps:

Click the pattern you want to view, and click <Zoom Object> from the menu. The selected object will be displayed in maximum level in the work area.

Zoom Hoop

Path: <Zoom Hoop>

Description:

Zoom in and view the selected hoop in the maximum level within the workspace.

Steps:

Click <Zoom Hoop> from the menu to display in maximum level in the work area.

● Edit Tools

Select All

Path: <Select All>

Description: Select all the objects in the workspace.

Steps: Click <Select All> from the menu.

Shortcut key: Ctrl+A(Windows system) / Command+A(OS system)

Measure

Path: <Measure>

Description: Measure the actual length of the workspace.

Steps:

Click <Measure> from the menu. The mouse will show "+", press and drag the mouse cursor in the workspace. The measurement results will be displayed in the program.

Shortcut key: Ctrl+M(Windows system) / Command+M(OS system)

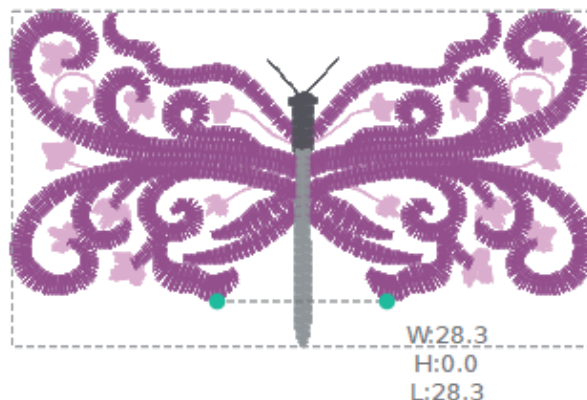

● Group Objects



Group Objects

Path: <Group>

Description:

Select multiple objects and group them together as a single unit to edit and design.

Steps: Select the objects you want to group, and click <Group> from the menu.

Shortcut key: Ctrl+G(Windows system) / Command+G(OS system)

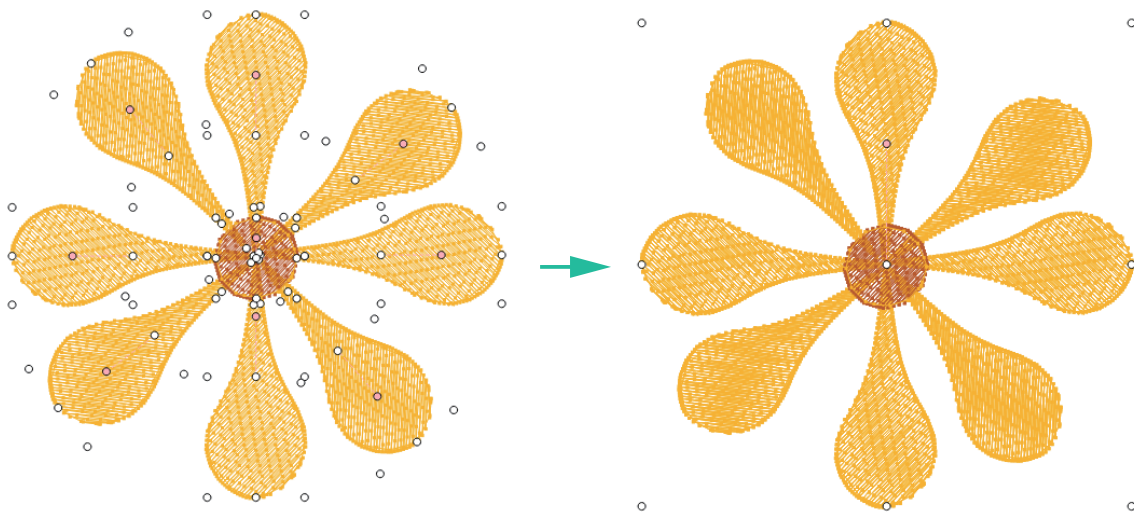

※ The group function is an one time function. If you want to group multiple group objects, please disengage the grouped objects first and then group all objects again at once.

Ungroup Object

Path: <Ungroup Object>

Description: Select the group you want to disengage and restore it to separate objects.

Steps: Click the objects you want to ungroup, and click <Ungroup Object> from the menu.

Shortcut key: Ctrl+U(Windows system) / Command+U(OS system)

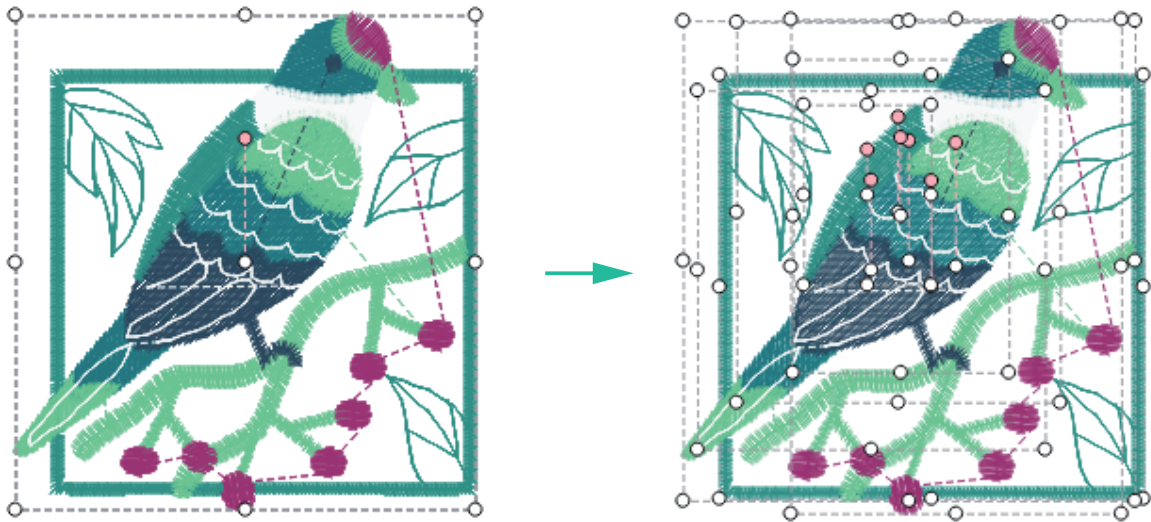

● Edit Size

Lock Proportion

Path: <Edit Size>

Description:

Edit the size of the selected object and set the aspect ratio to fixed or not.

Steps:

1. Click the object you want to edit, and click <Edit Size> from the menu.
2. Select the "Aspect ratio" ON/OFF (a), when it's set as ON (the pattern is highlighted grey ), the original aspect ratio will be maintained.
3. To adjust the object to a specific size, click the size option (b) and entering a value in the Width or the Height box to adjust the size.
4. To adjust the object size to a specific percentage, click the percentage option (c) and entering a value in the Width or the Height box to resize it.

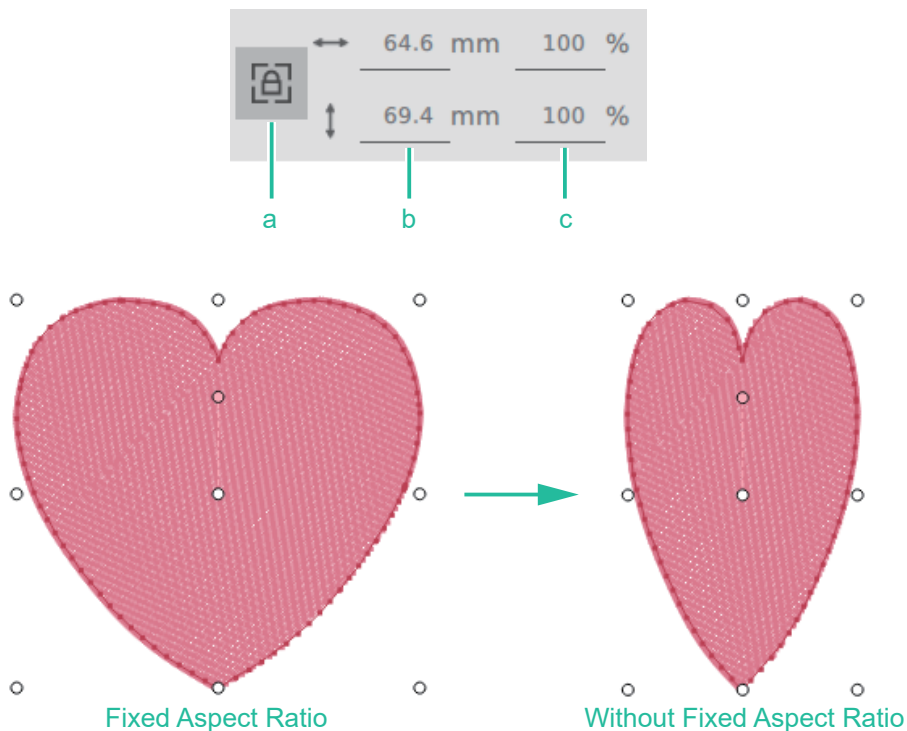

Rotate

Path: <Rotate>

Description: Edit the rotation angle of the selected object.

Steps:

Click the object you want to edit the rotation angle, and enter the angle value from 0~359 in the field.

Rotate object manually

Steps:

1. Click the object you want to edit.
2. Move the cursor to the pink control point above the center of the selected object. When the icon of the cursor is switched to  , press and hold the left mouse button to rotate it.

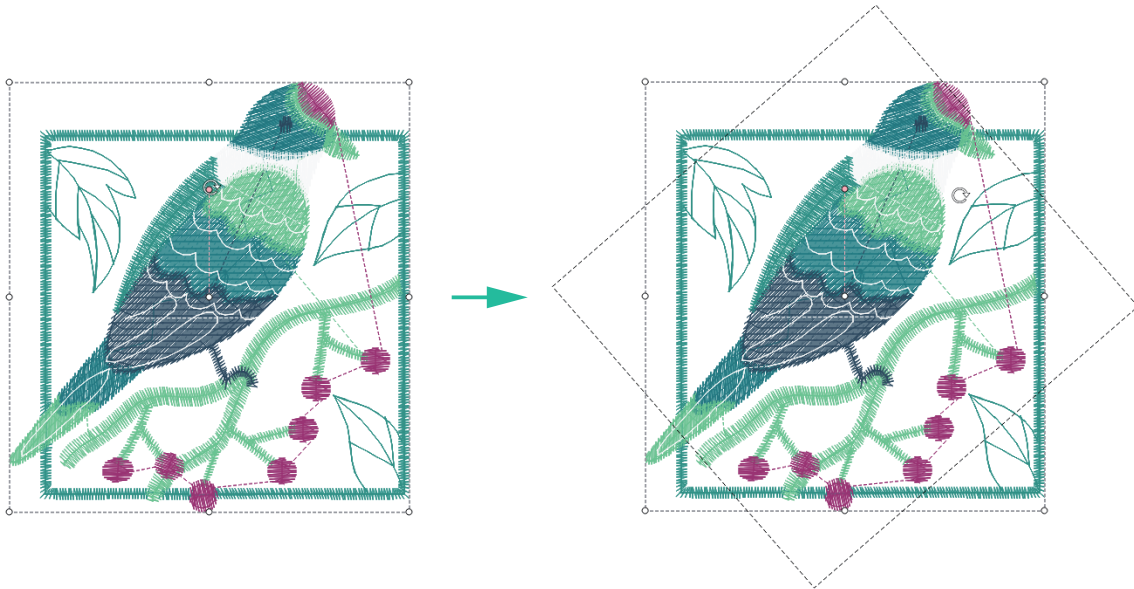

● Horizontal Or Vertical Flip Objects

▶◀ Flip Horizontal

Path: <Flip Horizontal>

Description: To flip the selected object horizontally.

Steps:

Click the object you want to flip horizontally, and click <Flip Horizontally> from the menu.

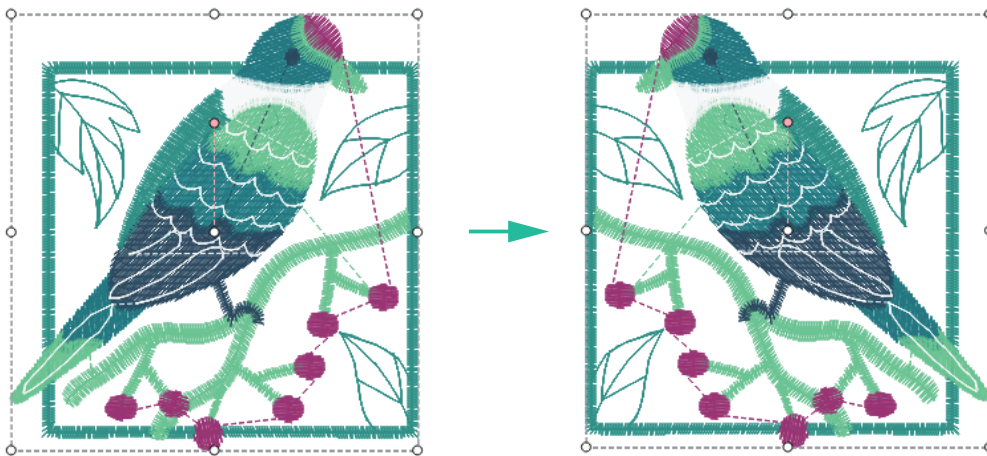

⬇️⬆️ Flip Vertical

Path: <Flip Vertical>

Description: To flip the selected object vertically.

Steps:

Click the object you want to flip vertically, and click <Flip Vertically> from the menu.

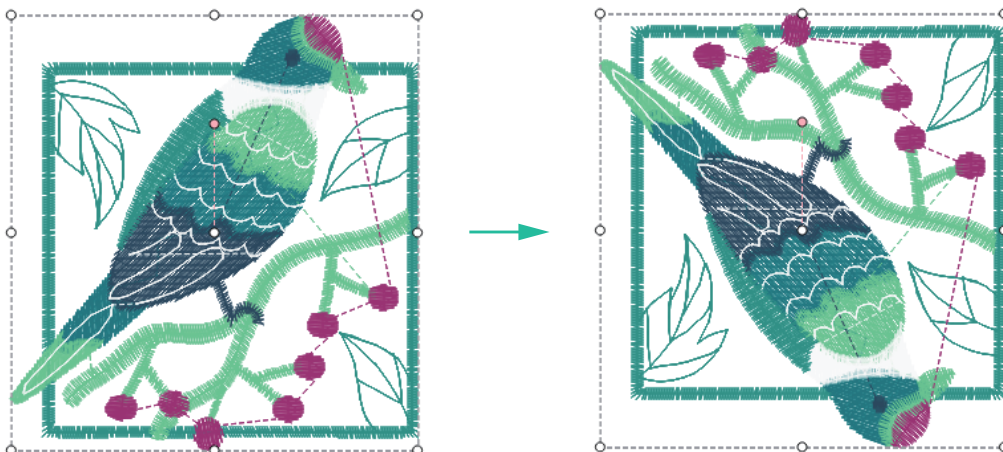

● Align

|≡ Align Left

Path: <Align Left>

Description:

When 2 or more objects are selected and using this feature, all objects will be left aligned to the leftmost object.

Steps:

Click <Align Left> from the menu.

Shortcut key:

Press "Ctrl" key with the mouse to click on selecting objects, it can select multiple or reduce objects.

Ctrl key (for Windows) / Command key (for Mac OS)

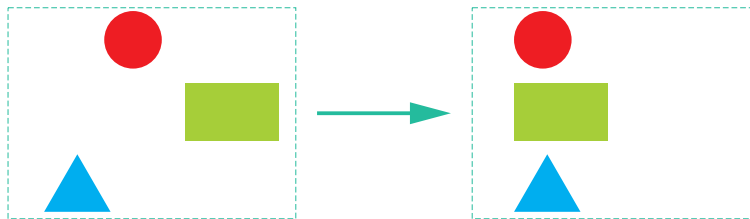

⊕ Align Middle

Path: <Align Middle>

Description:

When 2 or more objects are selected and using this feature, all objects are aligned to the one on in the vertical center.

Steps:

Click <Align Middle> from the menu.

Shortcut key:

Press "Ctrl" key with the mouse to click on selecting objects, it can select multiple or reduce objects.

Ctrl key (for Windows) / Command key (for Mac OS)

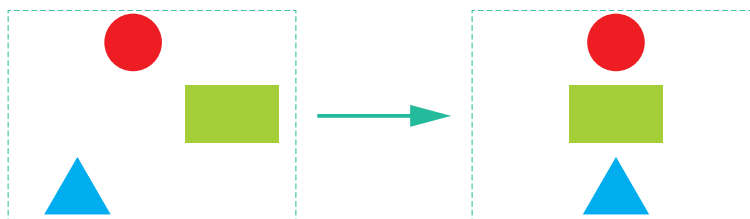

Align Right

Path: <Align Right>

Description:

When 2 or more objects are selected and using this feature, all objects are aligned to the one on the far right.

Steps:

Click <Align Right> from the menu.

Shortcut key:

Press "Ctrl" key with the mouse to click on selecting objects, it can select multiple or reduce objects.

Ctrl key (for Windows) / Command key (for Mac OS)

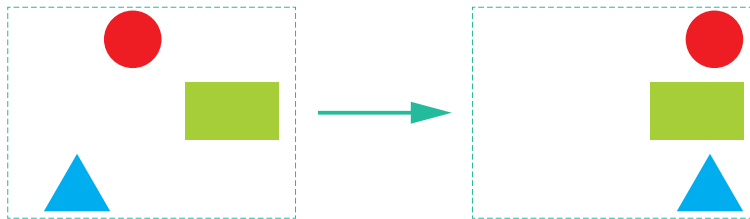

Align Top

Path: <Align Top>

Description:

When 2 or more objects are selected and using this feature, all objects are aligned to the one on the topside.

Steps:

Click <Align Top> from the menu.

Shortcut key:

Press "Ctrl" key with the mouse to click on selecting objects, it can select multiple or reduce objects.

Ctrl key (for Windows) / Command key (for Mac OS)

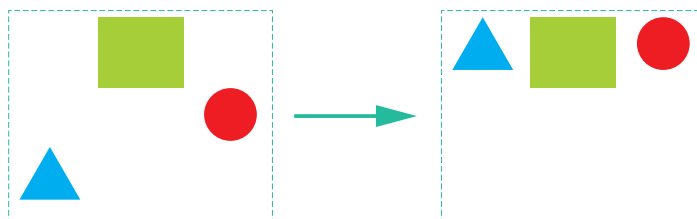

Align Center

Path: <Align Center>

Description:

When using "Select All" function or drag-select multiple objects, all objects are aligned to the one on in the horizontal center.

Steps:

Click <Align Center> from the menu.

Shortcut key:

Press "Ctrl" key with the mouse to click on selecting objects, it can select multiple or reduce objects.

Ctrl key (for Windows) / Command key (for Mac OS)

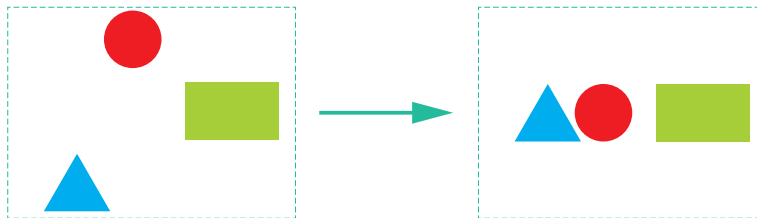

Align Bottom

Path: <Align Bottom>

Description:

When 2 or more objects are selected and using this feature, all objects are aligned to the one on the downmost.

Steps:

Click <Align Bottom> from the menu.

Shortcut key:

Press "Ctrl" key with the mouse to click on selecting objects, it can select multiple or reduce objects.

Ctrl key (for Windows) / Command key (for Mac OS)

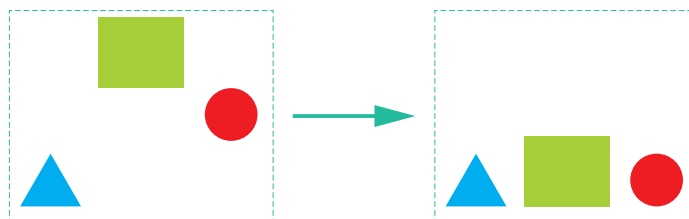

 **Align Hoop Center**

Path: <Align Hoop Center>

Description:

When objects are selected and using this feature, all objects are aligned to the hoop center.

Steps:

Click <Align Hoop Center> from the menu.

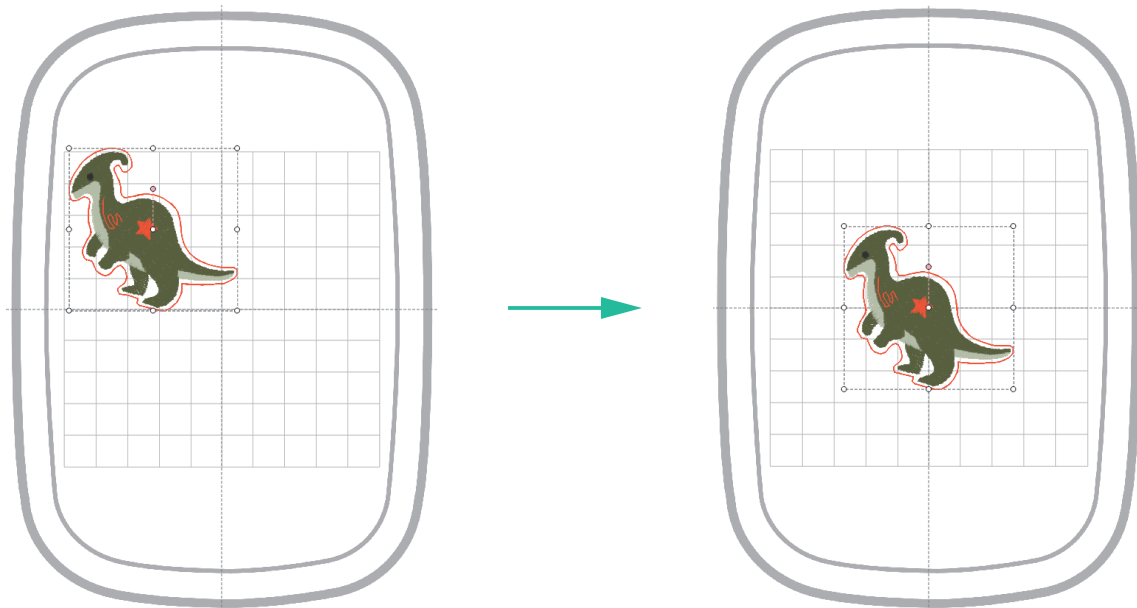

● Array

Copy Object To Top

Path: <Copy object to top>

Description:

Click the object and use <Copy the objects spacing> and <Copy the objects number of times> to duplicate the objects to the upper position.

Steps:

Click <Copy object to top> from the menu.

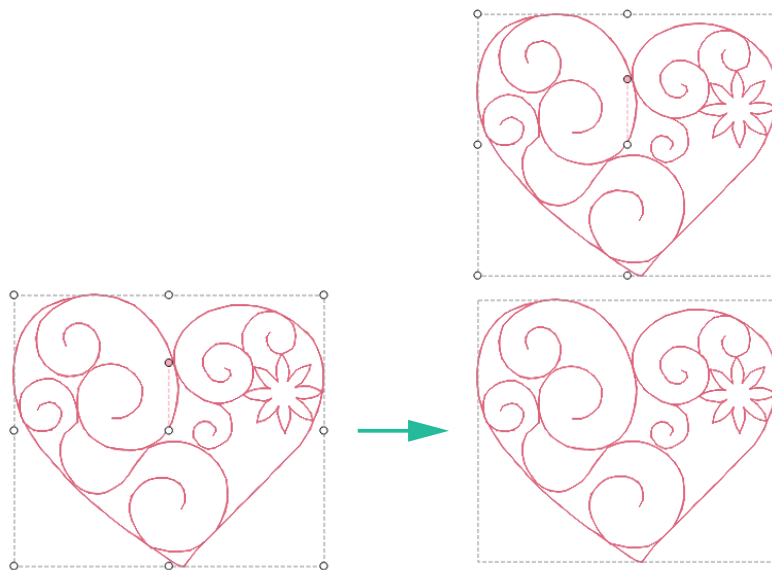



Copy Object To Bottom

Path: <Copy object to bottom>

Description:

Click the object and use <Copy the objects spacing> and <Copy the objects number of times> to duplicate the objects to the bottom position.

Steps:

Click <Copy object to bottom> from the menu.

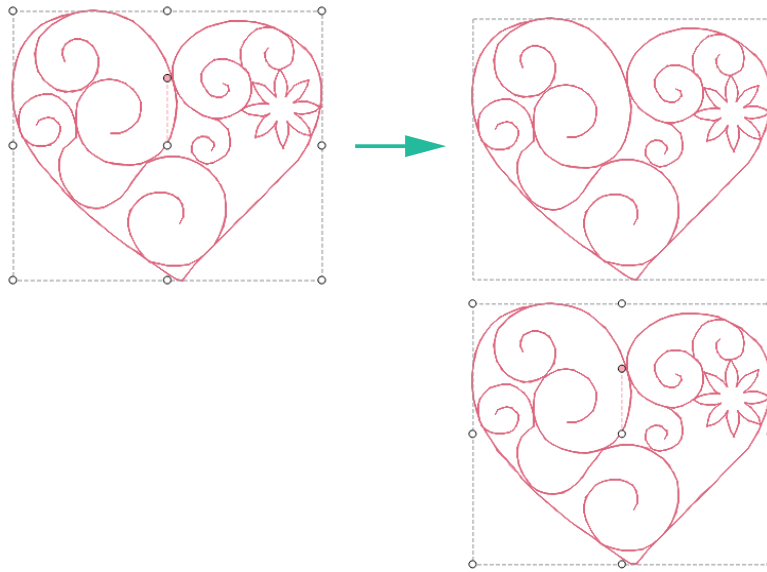

Copy Object To Left

Path: <Copy object to left>

Description:

Click the object and use <Copy the objects spacing> and <Copy the objects number of times> to duplicate the objects to the left side position.

Steps:

Click <Copy object to left> from the menu.

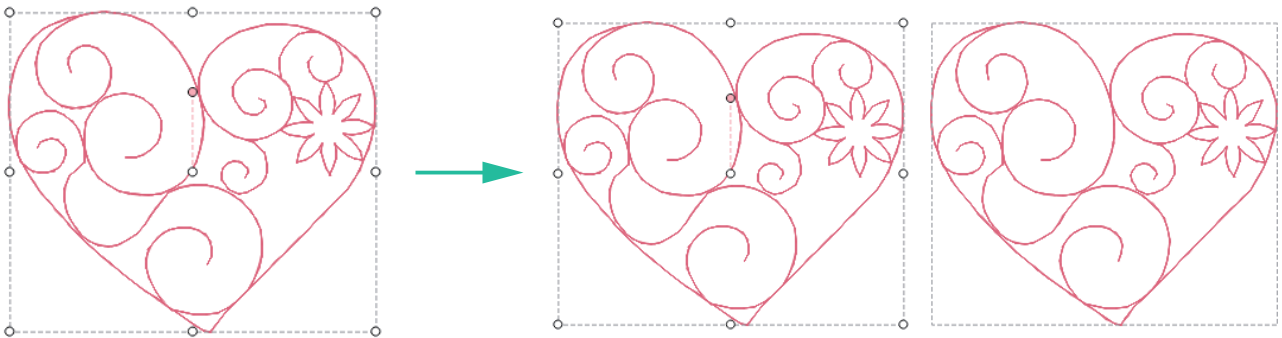

Copy Object To Right

Path: <Copy object to right>

Description:

Click the object and use <Copy the objects spacing> and <Copy the objects number of times> to duplicate the objects to the right side position.

Steps:

Click <Copy object to right> from the menu.

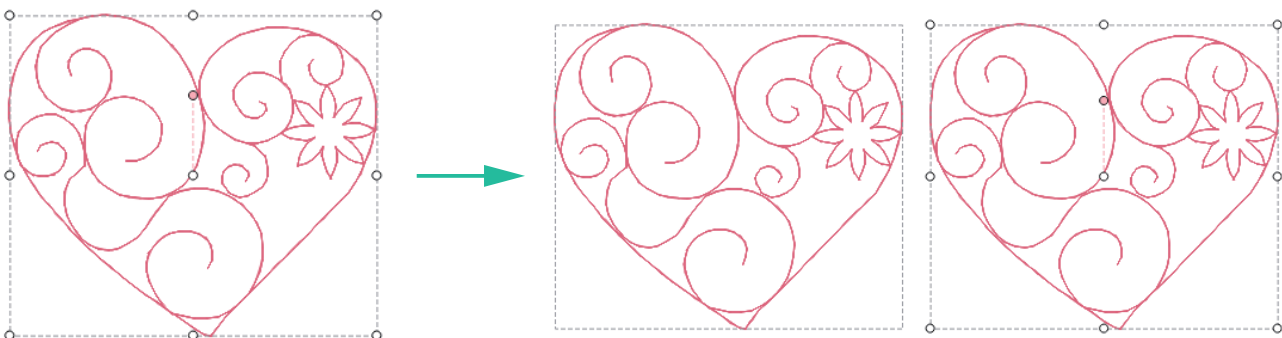

Copy Object To Four Directions

Path: <Copy object to four directions>

Description:

Click the object and use <Copy the objects spacing> and <Copy the objects number of times> to duplicate the objects to the four direction positions.

Steps:

Click <Copy object to four directions> from the menu.

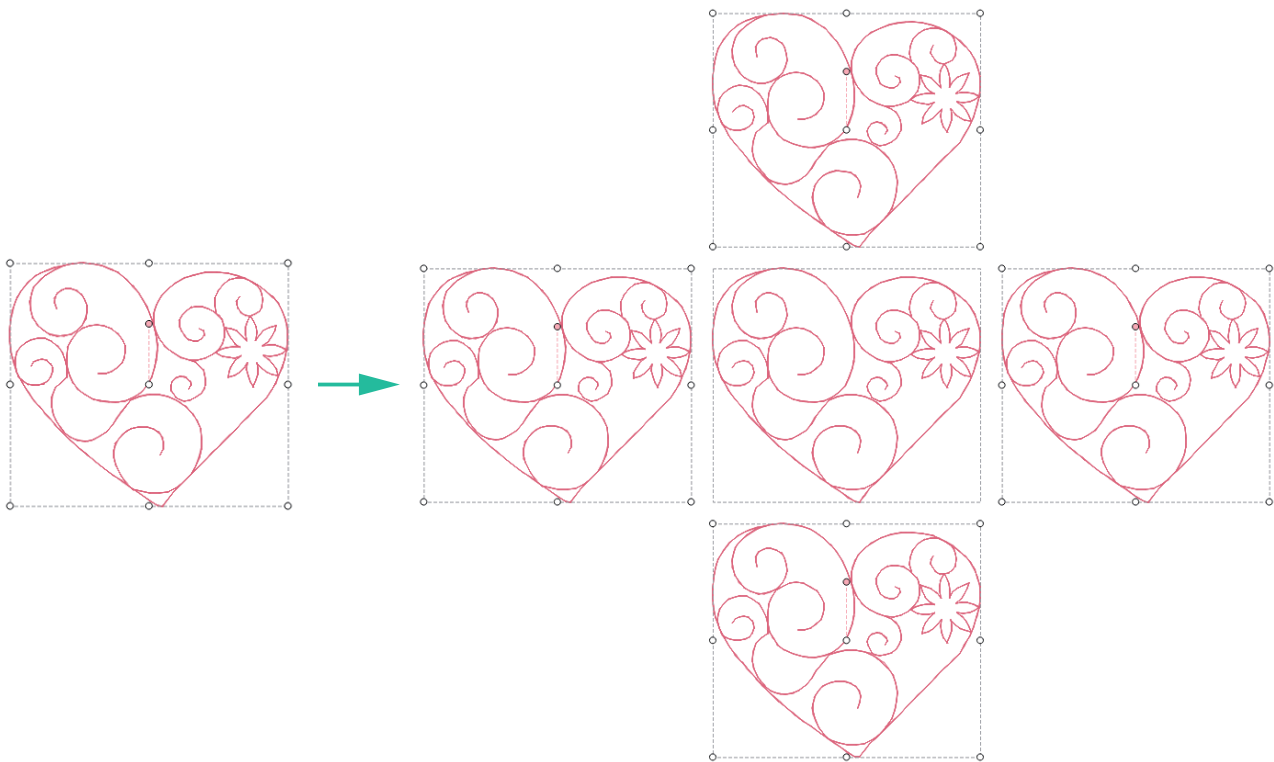

Copy With Flip

Path: <Copy with flip>

Description:

Click the object you want to copy and use <Copy with flip> to flip the duplicate object vertical or horizontal. (Choose the flip function, the button background color will be marked in grey .)

Steps:

Click <Copy with flip> from the menu.

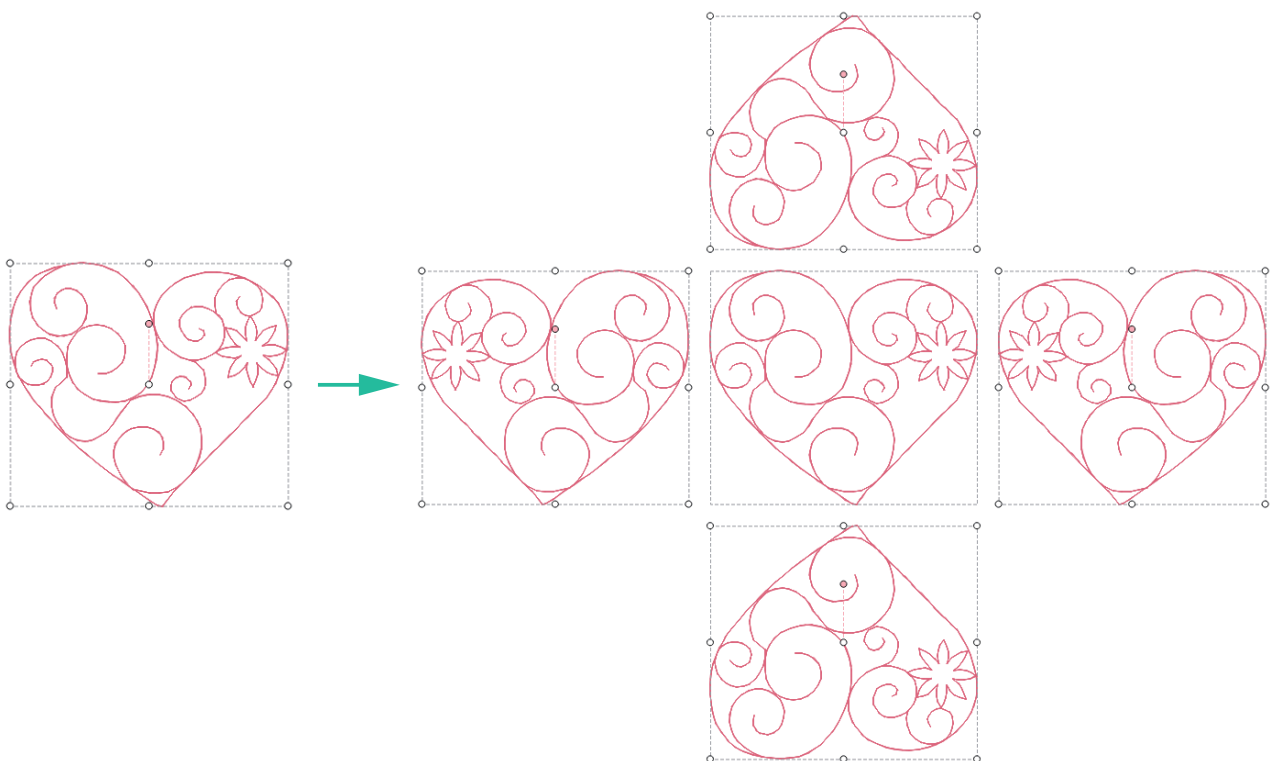

Text Manager

● Edit Text

T+ Text Tool

Path: <Text Tool>

Description:

The text tool has 11 built-in fonts, and the text can enter by using the text icon on the sub-screen or use the keyboard to enter the text directly.

In addition to set the text spacing, it also can change the font size (the defaulted font size is 10mm). The drop-down menu provides 5 font sizes. When the text is inserted into the editing screen, you can use the size adjustment function or use the mouse to adjust the size arbitrarily.

Steps:

1. Click <Text Tool> from the menu, the mouse cursor will change to .
2. Click on the working area where you want to enter the text.
3. In the pop-up screen, it will show all characters of this font, you can ①select the text direction, ②fonts, ③enter the text, ④select the font size, and ⑤set the text spacing in sequence.

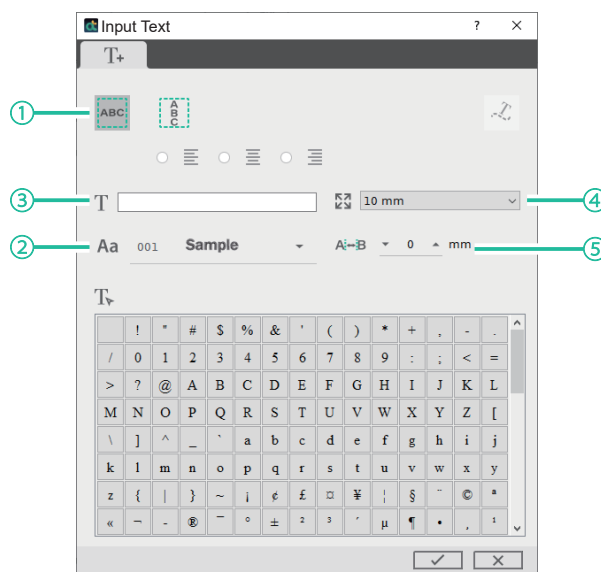

 Text Align Horizontal.

 Text Align Vertical: The available align type are  Left,  Center,  Right.

 Select Size: The available size are 10, 20, 30, 40, 50mm.

Aa Select Character: 11 built-in fonts.

Ai-B Spacing: -10(minimum)~0.0(default)~+30.0(maximum), unit: mm.

4. Click ✓, the text you have designed will display in the working area.

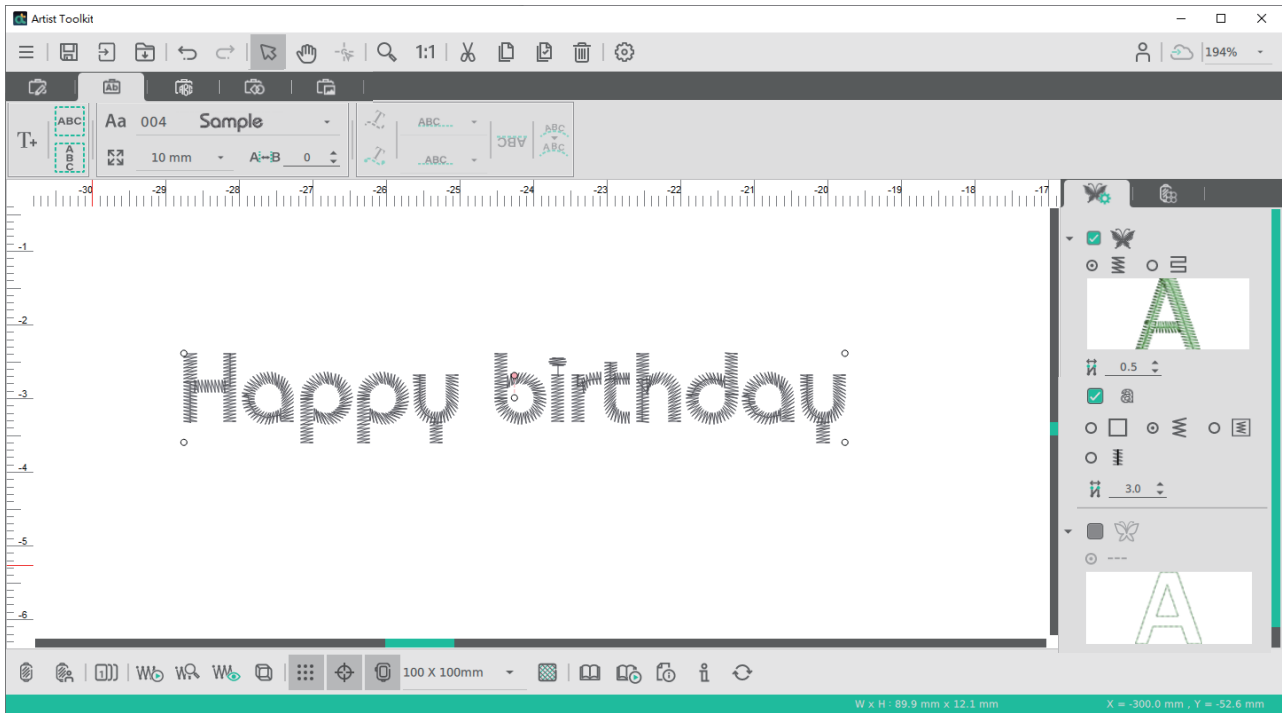

※ To edit the generated text again, you can double-click the left button of the mouse and the editing box will appear or click the <Text Tool> on the menu to use the font size selector, or use the mouse to adjust the font size.

● Text Align Path

Text Align Path

Path: <Text Align Path>

Description:

Use the generated text and drawn lines or cached graphics to align the text path. You can edit the line shape, or change the font, edit content, size, and spacing.

Steps:

1. Select the text and line or cache graphics.
2. Click <Text Align Path> on the menu, and the text will align the path.

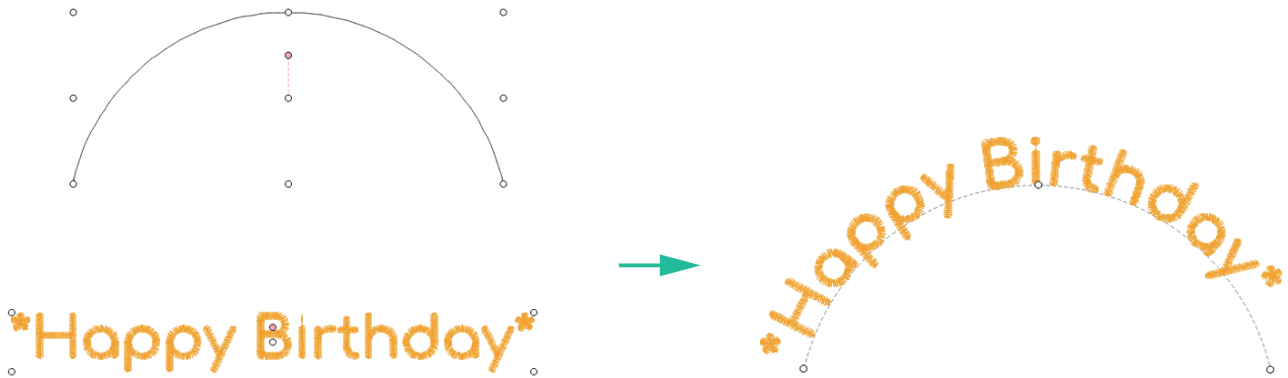

3. Text path align type.

Horizontal type:

Align Left  , Align Middle  , Align Right  , Distribute Horizontally  .

Vertical type:

Align Bottom  , Align Center  , Align Top  .

 Flip Vertical: To turn an object upside-down following the path.

 Fixed text direction: text angle will not adjust following the path.



4. To separate the text and line, can choose <Horizontal Text> or <Vertical Text>

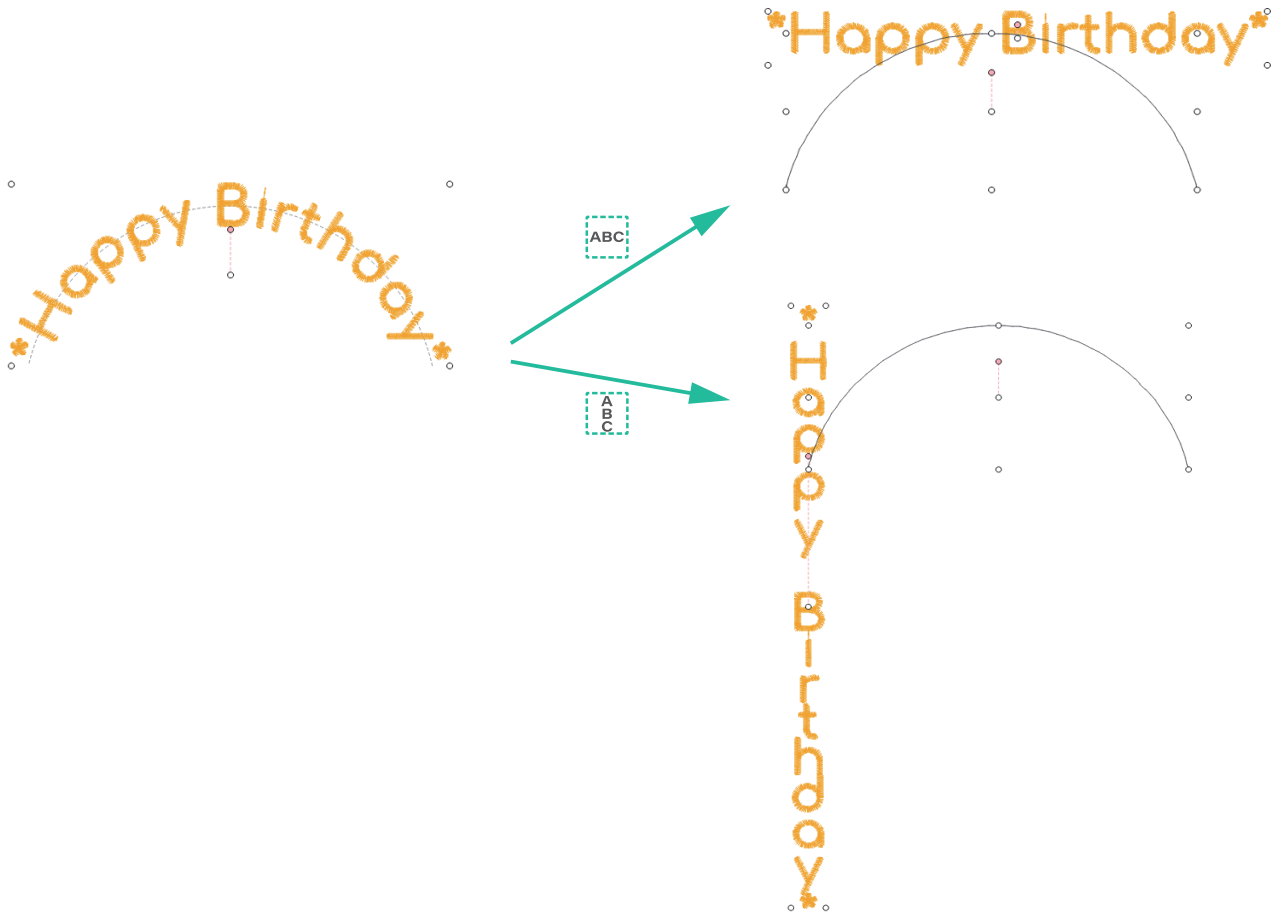

Monogram

● Monogram



Monogram Text Tool

Path: <Monogram Text Tool>

Description:

Monogram embroidery alphabets (including 26 uppercase alphabets), 3, 2 and 1 Letter monogram, 5 style of monogram fonts, and with variety of decorative frames can be selected.

Steps:

1. Click <Monogram Text Tool> on the menu, the mouse cursor will switch to .
2. <Monogram> contains alphabets, ①font styles, ②3, 2 and 1 Letter monogram. ③Enter the alphabets by keyboard or click from the pop-up screen, ④can choose design with decorative frames or not. ⑤The designed monogram will appear in the preview screen.

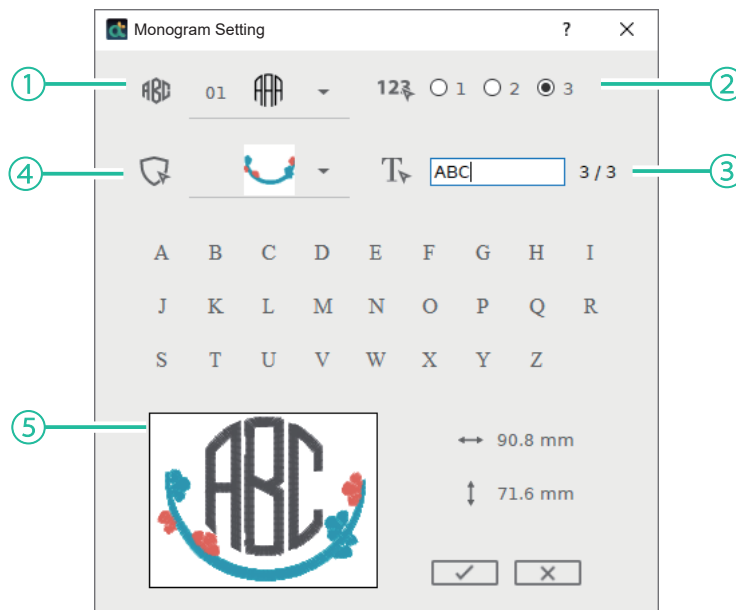

Text Font: 5 style of monogram fonts.



Character number: 3, 2 and 1 Letter monogram.



Select Frame: The frames will be varied based on the fonts.



Text: Including 26 uppercase alphabets.

3. Click on ✓ the editing area, and designed monogram will display on it.

If you want to modify the design, select the monogram, double click the left mouse button quickly or click <Monogram Text Tool> on the menu, the editing box will appear.

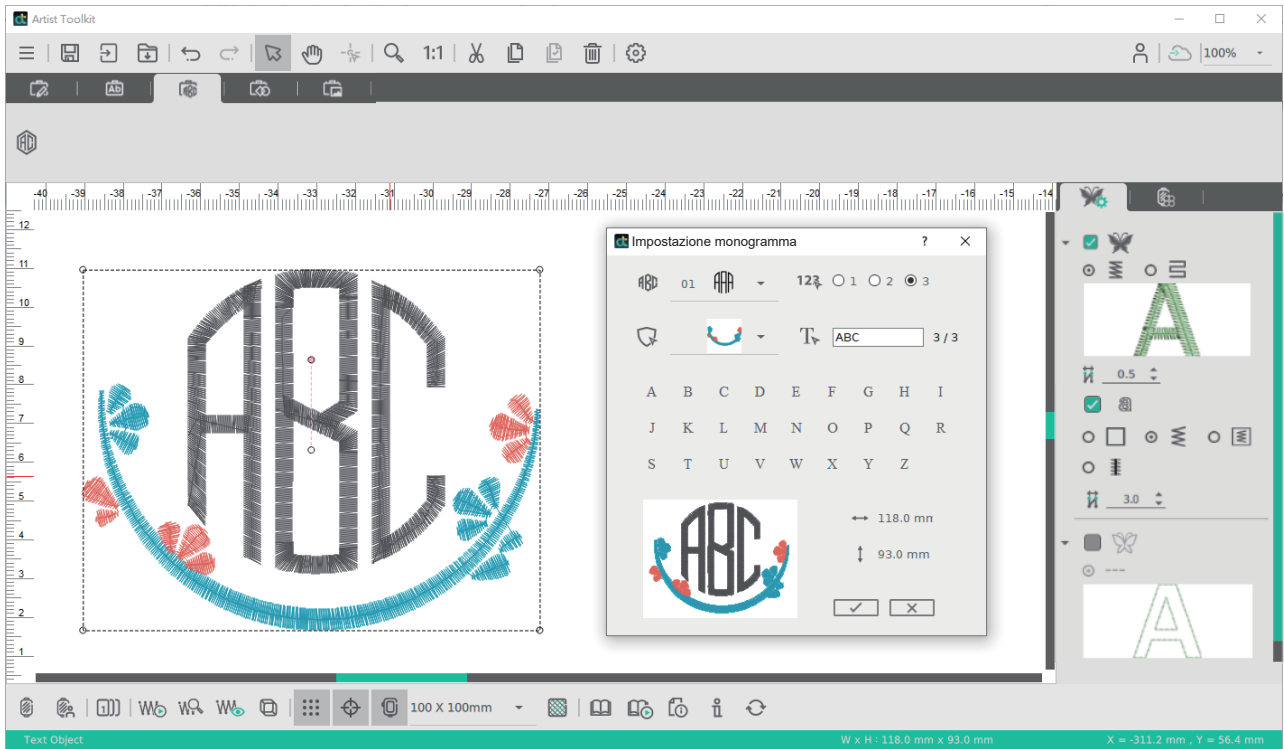

Paint Mode

● Paint Function



Draw Polyline

Path: <Draw Polyline>

Description:

Draw a series of continuous line segment. You can click the right mouse button to return to the last position ; to end the drawing, double click the left mouse button to finish the drawing.

Steps: Click <Draw Polyline> on the menu.

Shortcut key:

Draw a line with "Ctrl" key to draw vertically or horizontally.

Ctrl (Windows system) / Command (OS system)



Draw Curve

Path: <Draw Curve>

Description:

Draw a continuous curve. You can click the right mouse button to return to the last position; to end the drawing, double click the left mouse button to finish the drawing.

Steps: Click <Draw Curve> on the menu.



Draw Arc

Path: <Draw Arc>

Description:

To create an arc, click on the workplace to set the start point. Then decide the arc's length and click to set the end point of the arc. Move the mouse cursor until the desired arc shape and size is previewed, and then click to set the arc.

Steps: Click <Draw Arc> on the menu.

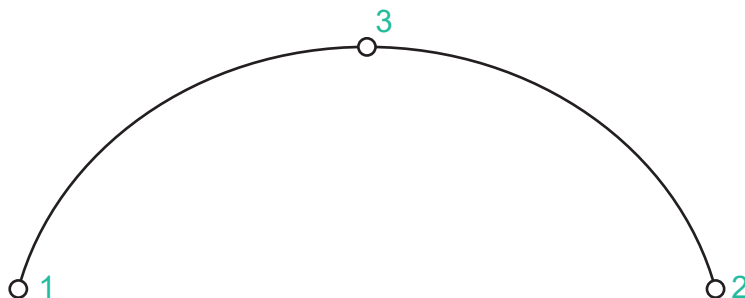

Paint Mode

Path: <Paint Mode>

Description:

It can draw 12 shapes by the graphic tool, such as heart, star or polygonal.

Steps:

Click <Paint Mode> on the menu and select the desired pattern. Click on workplace and drag the mouse cursor to create the graphic.



Draw Rectangle



Draw Rhombus



Draw Ellipse



Draw Shield-1



Draw Octagon



Draw Shield-2



Draw Triangle



Draw Pentagon



Draw Star



Draw Dart



Draw Heart



Draw Water

 **Open curve**

Path: <Open Curve>

Description:

Use graphics tablets or mouse to draw an open curve.

Steps:

Click <Open Curve> to draw an open curve. Each curve is a single object which can be edited individually.

 **Closed curve**

Path: <Closed Curve>

Description:

Use graphics tablets or mouse to draw a closed curve.

Steps:

Click <Closed Curve> to draw a closed curve. When the start point and end point are close, release the mouse button to finish drawing closed curve(photo 1).

When click <Closed Curve>, it can also connect two points and the separated lines will be combined into one.(photo 2-4)

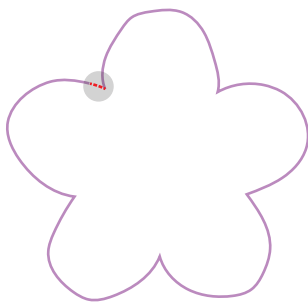

Photo 1



Photo 2



Photo 3



Photo 4



Closed outline with filling stitches

Path: <Closed outline with filling stitches>

Description:

Use the mouse or an external drawing board to draw closed objects. Each object can be imported with different stitches and related parameters can be adjusted.

Steps:

Click the "Closed outline with filling stitches" menu to start drawing the object. From the beginning to the end of the stroke, a closed preview segment is maintained in the middle. After the stroke stops, it becomes a closed object.

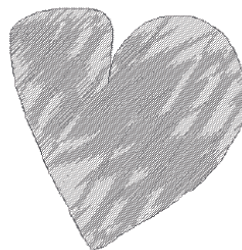

Pressure sensitivity

Path: <Pressure Sensitivity>

Description:

Control your stroke with the force of your hand. (Recommend to use graphics tablets for better performance)

Steps:

Click <Pressure Sensitivity> and start to draw.

1. Drawing by tablets: control your stroke with the force of your hand.
2. Drawing by mouse: width is set by default.

※ Stitch Gauge: 1.0 (default), unit: mm.



The effect of Drawing
by tablets



The effect of Drawing
by mouse



Applique

Path: <Applique>

Description:

Applique Assistant

Draw a shape by the graphic tool and create an applique pattern by Applique Assistant.

※ Remark: After created the pattern, it will be stitch object and shows around the object in dotted line.

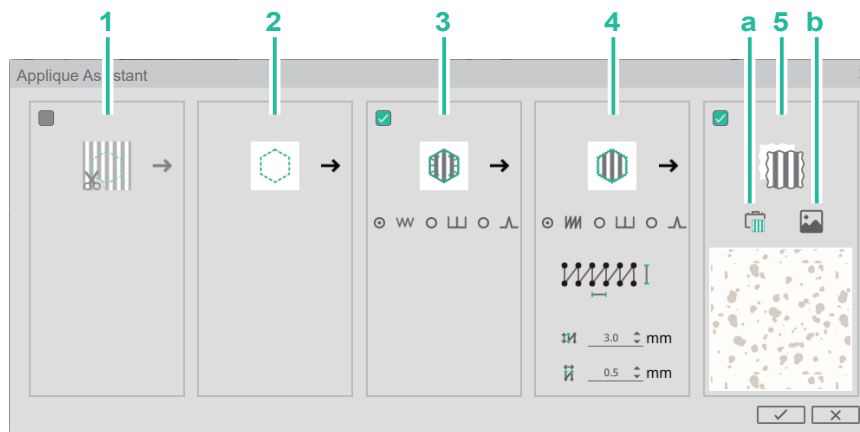

Steps:

Click <Applique> for Applique Assistant.

1. Applique materials: Specify cutting lines for the applique.
2. Applique Position:
 - Option 1: Specify cutting lines for the applique and cut the shape, and attach the appliqué piece.
 - Option 2: Sew the outline of the applique as running stitches and cut out.
3. Tack down: Select one of stitches from Satin stitch/E stitch/V stitch. The appliqué piece can be basted onto the base fabric.

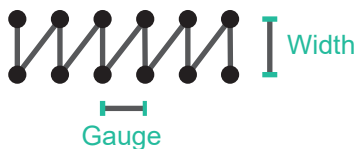

Satin stitch



E stitch



V stitch

4. Covering and select one of stitches from Satin stitch/E stitch/V stitch. Tack down will be cancelled when selecting E stitch or V stitch.

※ Satin stitch: width 2.0(min)-3.0(default)-10(max) mm

gauge 0.2(min)-0.5(default)-10(max) mm

※ E stitch: stitch length 2.0(min)-3.0(default)-10(max) mm

stroke height 1.0(min)-2.0(default)-10(max) mm

※ V stitch: stitch length 2.0(min)-3.0(default)-10(max) mm

stroke height 1.0(min)-2.0(default)-10(max) mm

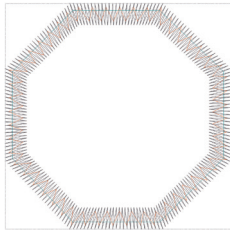

Satin stitch

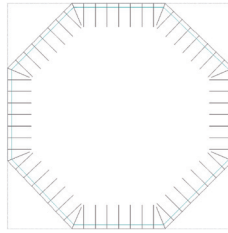

E stitch

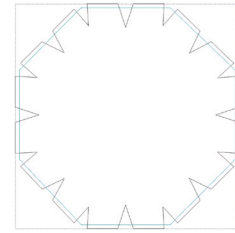

V stitch

5. Set the material: selecting built in material or load a image, it can simulate and preview.

a. There are 21 built in materials and 25 colors.

b. Please load desired image. Support format: *.jpg *.png *.gif *.bmp *.tif *.tiff

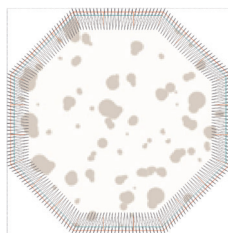

The simulation to applied the fabrics

Mark Stitch

Path: <Mark Stitch>

Description:

Use compound of fill stitch and satin fill stitch within stitching area to create a variety of different styles of Mark stitch.

Steps:

First, generate the area for fill stitch, select compound fill stitch or satin fill stitch, and then click the Mark Stitch icon to enter the execution screen.



Descriptions on the functions :

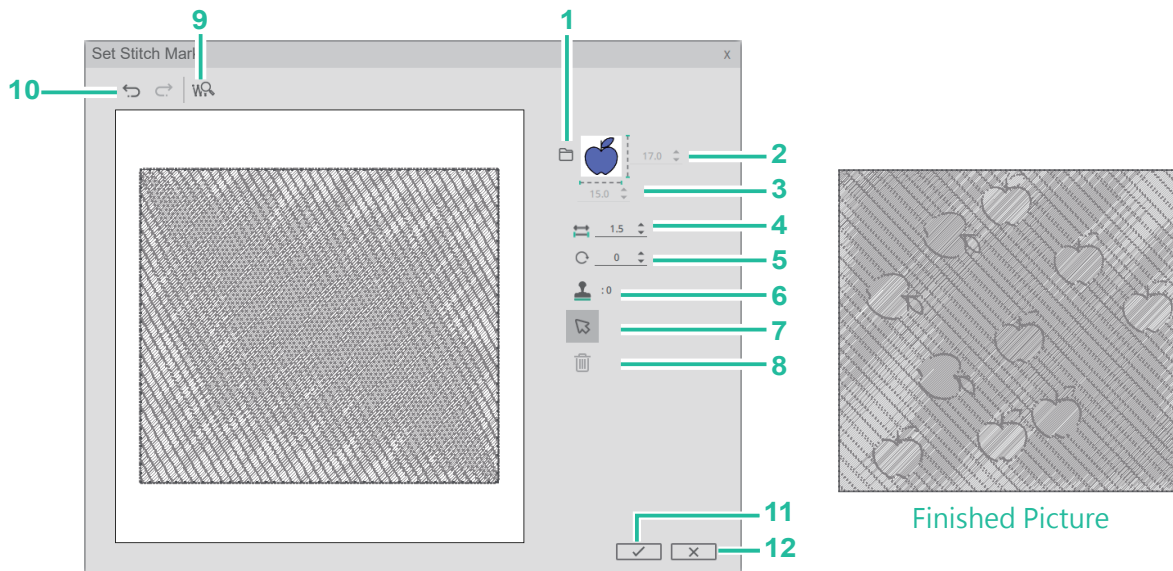

1. Go to <Set Mark Stitch>, click the pattern folder, and select the desired Mark stitch pattern. The darker or lighter colors of the pattern represent sunken or embossed stitches.

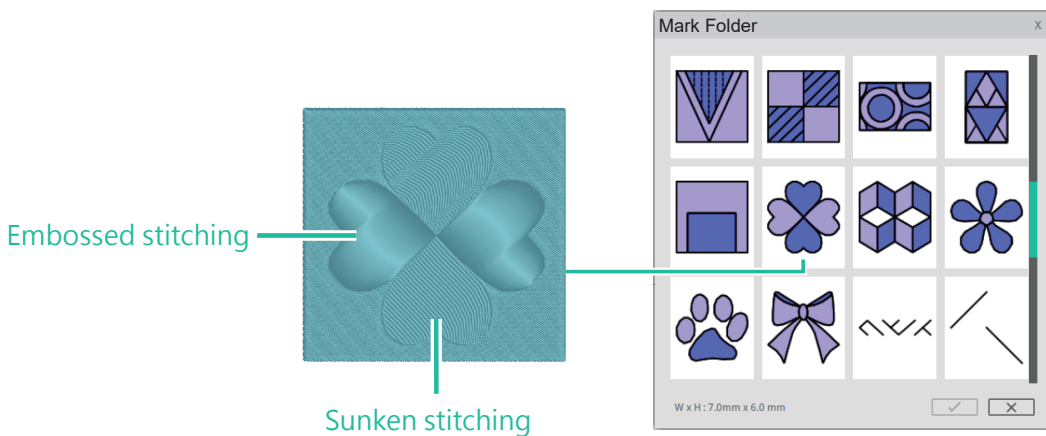

- 
2. Pattern height: Unit: mm, can only be set in Mark Stitch mode
 3. Pattern width: Unit: mm, can only be set in Mark Stitch mode
 4. Stitch size: Stitch 1.5 (default), unit: mm.
 5. Needle angle: Angle 0 (default), unit: degree.
 6. Stamp embroidery mode: In this mode, when you set the parameters of the pattern before Mark Stitch, the number of Mark Stitch patterns will be displayed synchronously.
 7. Selection mode: You can move, delete or adjust the stitch length and angle of the selected object
 8. Delete button: Delete the selected Mark Stitch image.
 9. Needle point preview: the needle points of the Mark Stitch can be displayed.
 10. Undo and Redo buttons.
 11. Done button: produces Mark Stitch stitches and returns to the main window.
 12. Close button: cancel the Mark Stitch output and return to the main window.

Photo Stitch

● Photo Stitch-Sub module 1



Random stitch

Path: <Random stitch>

Description:

Click on the icon of random stitch embroidery to create photo stitch images of random stitch embroidery.

Suggestions for using photos:

- The theme is clear and occupies a large proportion of the whole picture.
- The image should not be gray and dark. The brightness, contrast, and saturation can be adjusted in due course.
- The photo pixel is recommended not to be lower than 500 pixels.

1. Photo adjustment

Description:

After the image is selected, you can choose the style mode you want to produce, and make image adjustments for the image.

Step:

1. Click <Random Stitch Embroidery Module>  and select the image to be made into random stitch embroidery.

If you want to re-select the image, you can use the <Change Image File> function to re-select the image.

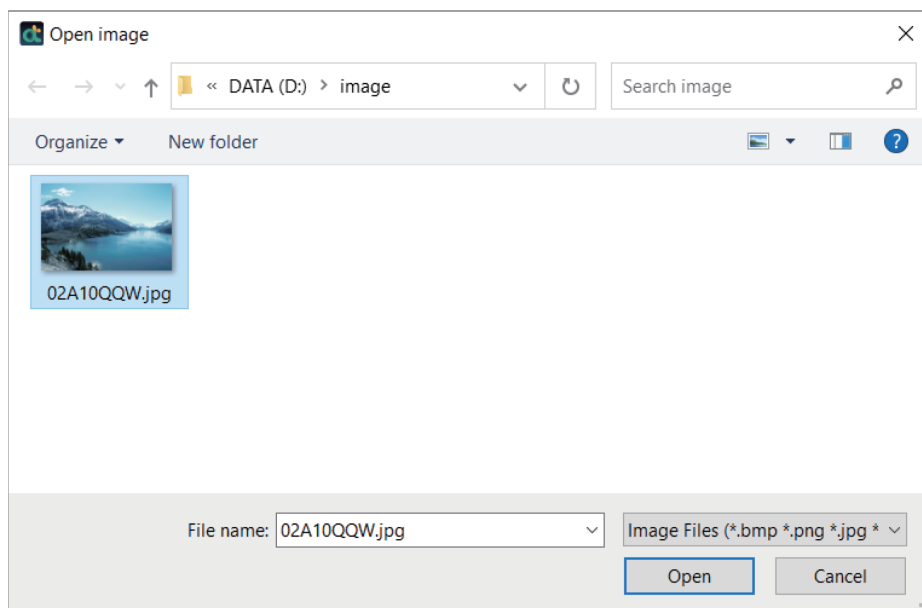

2. Select image mode, there are three modes (color/grayscale/monochrome) to choose from.

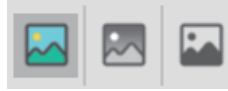

3. Click the <Next> button to enter the next step execution screen.

Function item description:

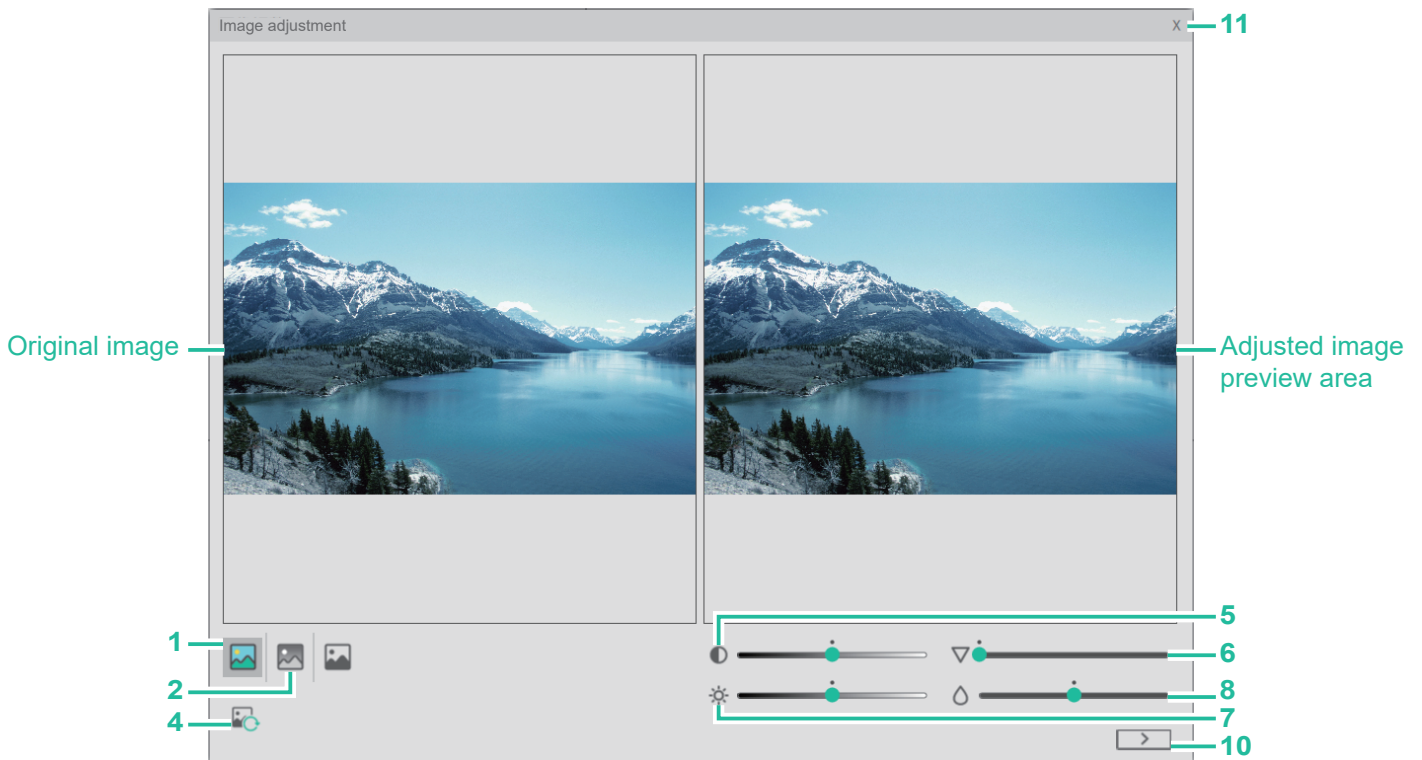

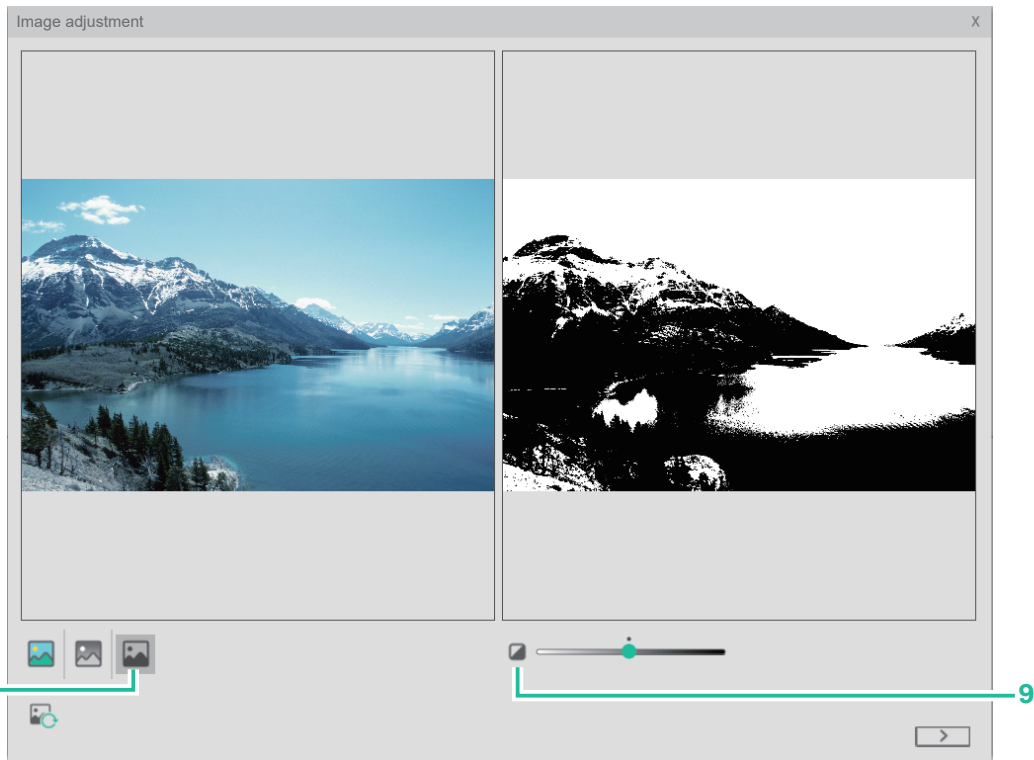

1. Color:

Generate color random stitch photo in stitch image.

2. Grayscale:

Generate grayscale random stitch photo in stitch image.

3. Monochrome:

Generate monochrome random stitch photo in stitch image.

4. Change picture file:

Change photo.

5. Contrast adjustment:

You can adjust the contrast of the photo to make the difference between light and dark more obvious.

6. Sharpness adjustment:

It can improve the sharpness of the photo, increase the contrast of the edge of the photo, and make the photo clearer.

7. Brightness adjustment:

You can adjust the lightness and darkness of the photo.

8. Saturation Adjustment:

You can adjust the vividness of the color of the photo.

9. Black and white ratio adjustment:

Adjust the black and white ratio of monochrome photos.

10. Next step:

Press the next step button to enter the next step execution screen.

11. Close:

Press the close button to cancel the image output of random stitch embroidery and return to the main window.

2. Image shape setting

Description:

Image shape setting.

Step:

1. Use the function buttons to edit the shape of the image, and use the mouse to click on the Bezier node to select the image position to be generated.

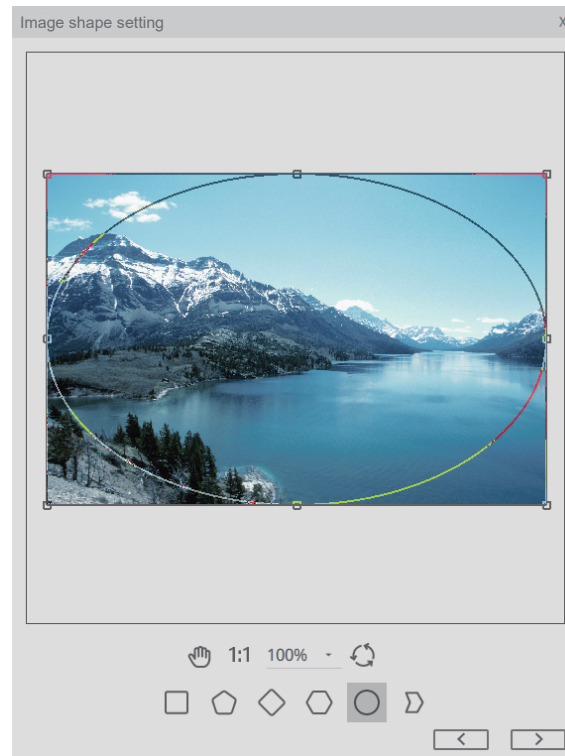

2. Click the <Next> button to enter the next step execution screen.

Function item description:

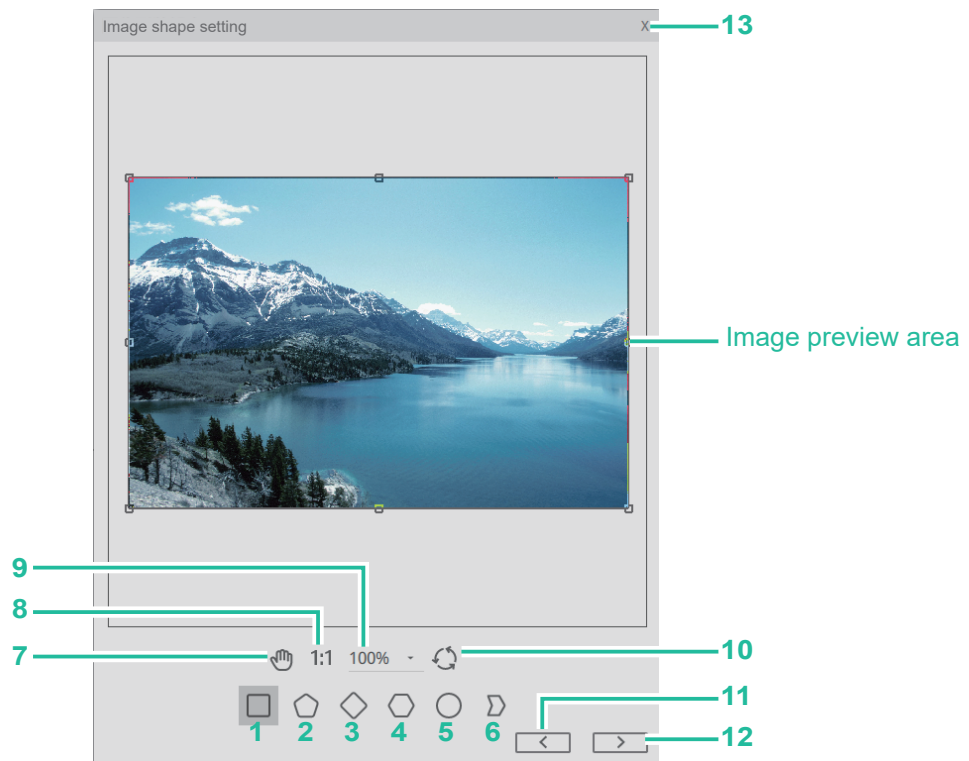

1. Rectangle:

The shape of the cropped image is a rectangle.

2. Pentagon:

The shape of the cropped image is a pentagon.

3. Rhombus:

The shape of the cropped image is rhombus.

4. Hexagon:

The shape of the cropped image is hexagon.



5. Oval:

The shape of the cropped image is oval.

6. Polygon:

The shape of the cropped image is in any shape. Use the mouse to click on the bezier curve, you can directly add nodes on the line, directly click the control point, can be used with the delete button to delete and move nodes.

7. Move:

Move the position of the preview workspace. After clicking this function and moving the mouse to the workspace, the mouse icon will change to a moving icon , at this time, click and hold the screen to drag the screen directly. Click <Move> again, the mouse will cancel the move function, and the mouse will return to the selection tool  . °

8. Return to original ratio:

Click this function, and the display ratio of the work area on the screen will be restored to 1:1.

9. Viewing ratio:

According to the selected ratio, adjust the display ratio of the work area on the screen, and the maximum can be zoomed to 200%.

10. Reset:

Return to the initial screen of graphic cutting.

11. Previous step:

Press the previous step button to return to the previous step execution screen.

12. Next step:

Press the next step button to enter the next step execution screen.

13. Close:

Press the close button to cancel the image output of random stitch embroidery and return to the main window.

3. Image size setting

Description:

Image size setting.

Step:

1. Use the function bar to directly input the image file size, or use the <Zoom to Embroidery Frame> function to adjust the size.
The size adjustment range is 30.0mm~300.0mm, if the size is not within this range, the next step cannot be performed.
2. Click the <Next> button to enter the next step execution screen.

Function item description:

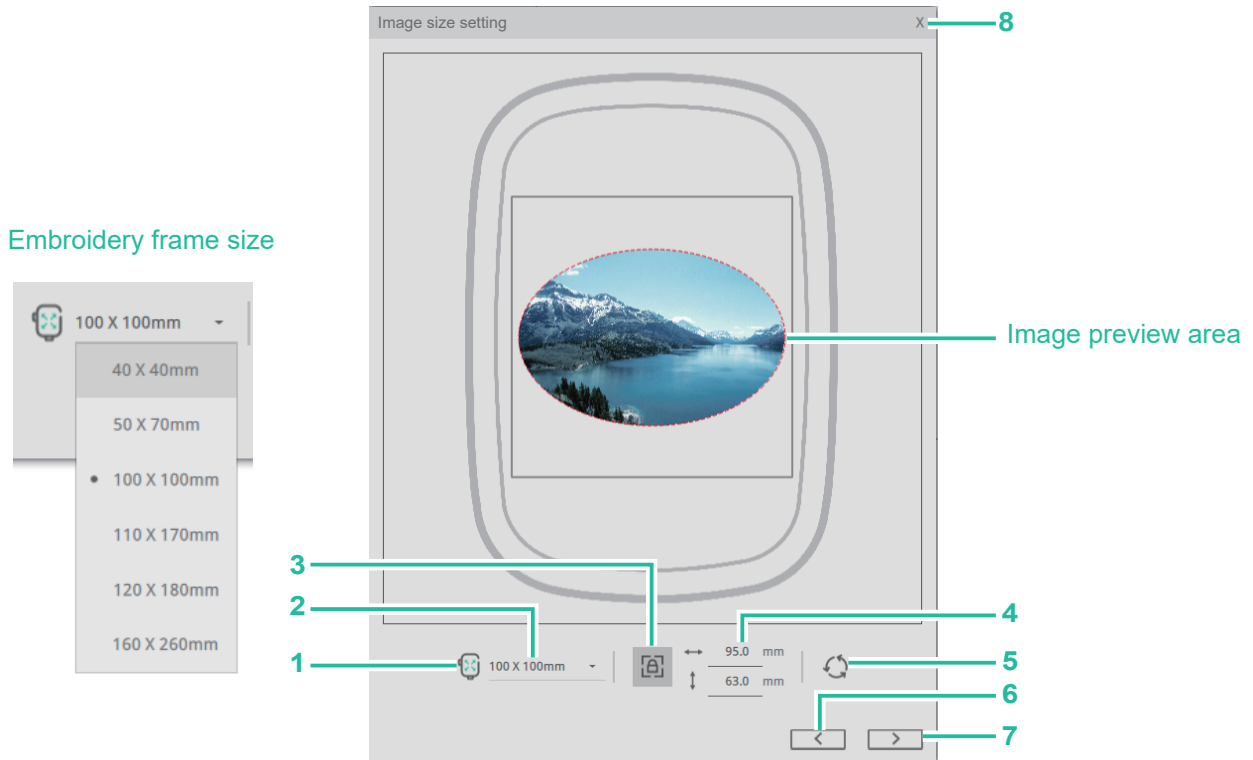

1. Zoom to the embroidery frame:

The size of the photo will fill the page proportionally according to the currently set frame size.

2. Change the size of the embroidery frame:

Click to change the size of the embroidery frame to change the current size of the frame.

3. Lock ratio:

Lock or not lock the photo size ratio.

4. Size display and adjustment:

Directly enter the size at the width/height, and the size can be entered up to the first decimal place.

5. Reset:

Return to the original size of the image.

6. Previous step:

Press the previous step button to return to the previous step execution screen.

7. Next step:

Press the next step button to enter the next step execution screen.

8. Close:

Press the close button to cancel the image output of random stitch embroidery and return to the main window.

4. Set parameters / Color change

Description:

Set relevant parameters for the output random stitch embroidery.

Step:

1. Click <Embroidery Thread Brand List> to select the embroidery thread color brand.
2. Enter the number of embroidery thread colors, 10 colors are preset, and the adjustable range is 4~50 colors. After thread brand and color are selected, the color can be adjusted independently and the reserved color function can be set. When the color is set as reserved color, please adjust again the embroidery thread brand, thread color, brightness and contrast, the reserved color will remain unchanged.
3. The image can be set according to the effect such as density, fineness, stitch distance and whether to use outer frame zigzag hemming and other functions.
4. Click <Update Preview>, the stitch preview will display the parameter setting results.

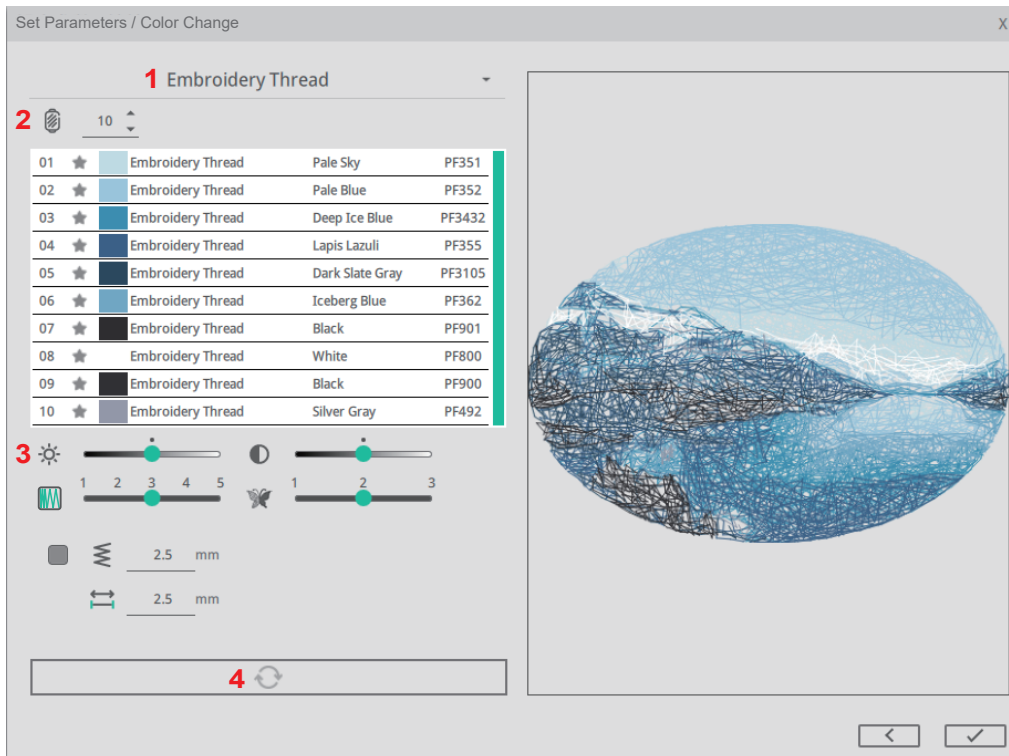

5. Click the  button to complete the random stitch embroidery image and return to the main window.

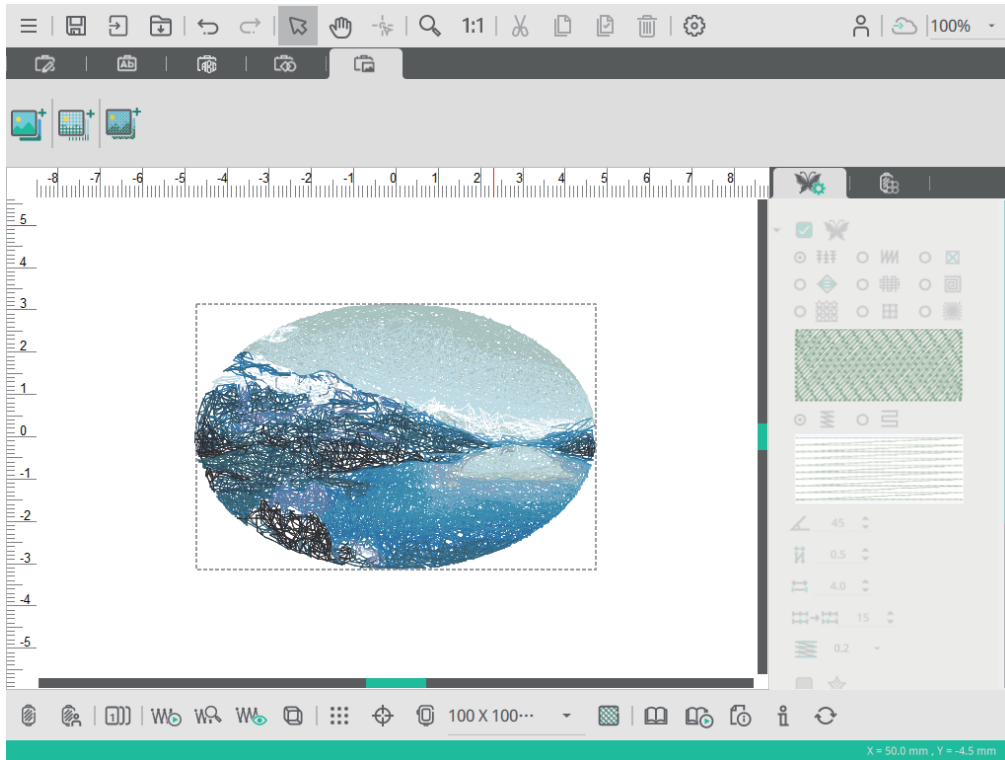

Function item description:

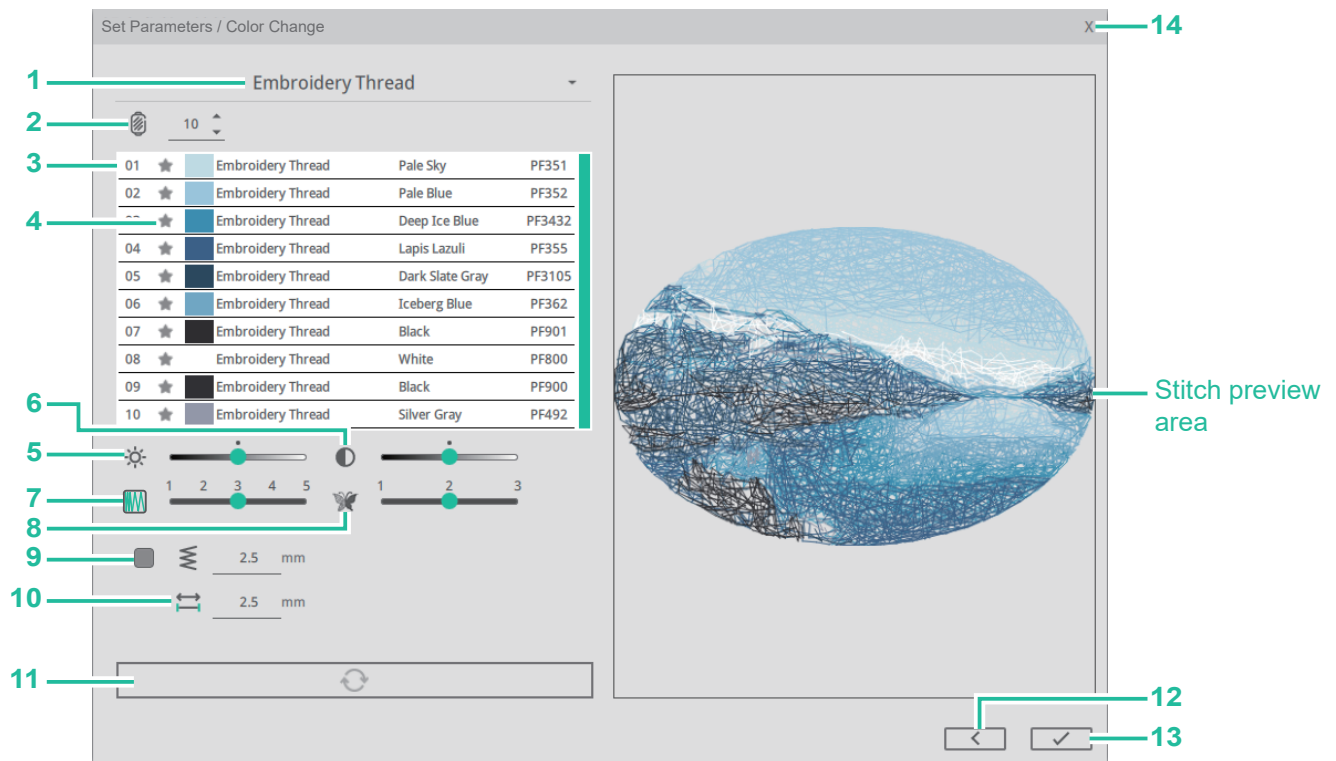

1. Thread color label list:

Press the thread color label setting to change the thread color label. When the reserved color function is activated, the color remains unchanged.

2. Number of colors:

Set the number of colors in the photo, the default is 10 colors, and the setting range is 4-50 colors. The actual output color number will be expressed according to the calculation result of the image file.

The number of colors can be directly input by the keys, or the up and down keys can be used to increase or decrease the color.

When the reserved color function is enabled, the minimum number of colors is the number of reserved colors.

3. Color information:

Display the color, brand, color description and color number, and modify the thread color brand and thread color for a single color.

Place the mouse on the color column (at this time the color column is grayed out), use the left mouse button to quickly click twice, and the window for modifying the brand color will appear. Click on the thread color to modify the thread color brand/color. When the retain color function is activated, the thread color modification function cannot be entered.

4. Reserved color:

Press the function of retaining thread color, the icon will be represented by blue-green ★, and the current color can be retained. To cancel the reserve function, click the icon again, and the icon will be represented by gray ★. The setting can be canceled. When the



function of retaining color is activated, the color changes brand or color number, the color remains unchanged.

5. Brightness adjustment:

Brightness adjustment can adjust the lightness and darkness of stitches. When the reserved color function is activated, the color remains unchanged.

6. Contrast adjustment:

Contrast adjustment can adjust the contrast of stitches, making the difference between light and dark more obvious. When the reserved color function is activated, the color remains unchanged.

7. Density adjustment:

Set image density, preset 3. The larger the adjustment number, the thinner the stitch density. The lower the adjustment number, the denser the stitch density.

8. Fineness adjustment:

Set the fineness of the image effect, preset 2. The larger the adjustment number, the finer the stitching effect. The smaller the adjustment number is, the less fine the stitching effect will be.

9. Outer frame zigzag hemming:

Set whether to add zigzag to the outer frame of the image, default/uncheck, when checked, default 2.5mm.

10. Stitch distance:

Set the stitch distance of the image, preset 2.5mm.

11. Update preview:

Press the <Update preview> button to regenerate a new stitch icon according to the adjusted parameters.

12. Previous step:

Press the previous step button to return to the previous step execution screen.

13. Completion:

Press the Finish button to produce random stitches and return to the main window.

14. Close:

Press the close button to cancel the image output of random stitch embroidery and return to the main window.

● Photo Stitch-Sub module 2



Overlap satin stitch

Path: <Overlap satin stitch>

Description:

Click on the icon of Overlap satin stitch embroidery to create photo stitch images of overlap satin embroidery.

Suggestions for using photos:

- The theme is clear and occupies a large proportion of the whole picture.
- The image should not be gray and dark. The brightness, contrast, and saturation can be adjusted in due course.
- The photo pixel is recommended not to be lower than 500 pixels.

1. Image adjustment

Description:

After the image is selected, you can choose the style mode you want to produce, and make image adjustments for the image.

Step:

1. Click <Overlap satin stitch embroidery module>  and select the image to be made into Overlap satin stitch embroidery.
If you want to re-select the image, you can use the <Change Image File> function to re-select the image.

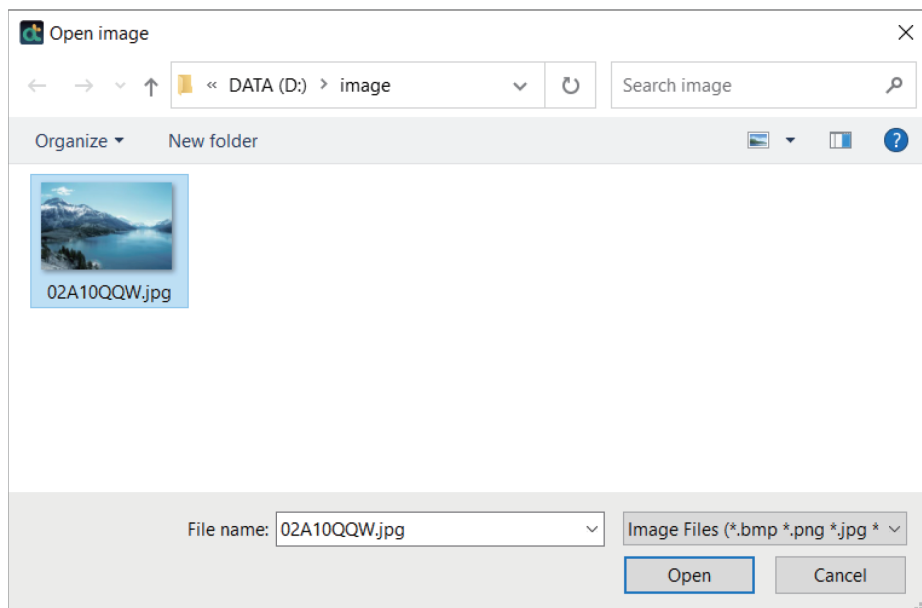

2. Select image mode, there are three modes (color/grayscale/monochrome) to choose from.

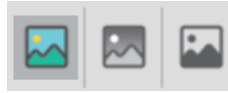

3. Click the <Next> button to enter the next step execution screen.

Function item description:

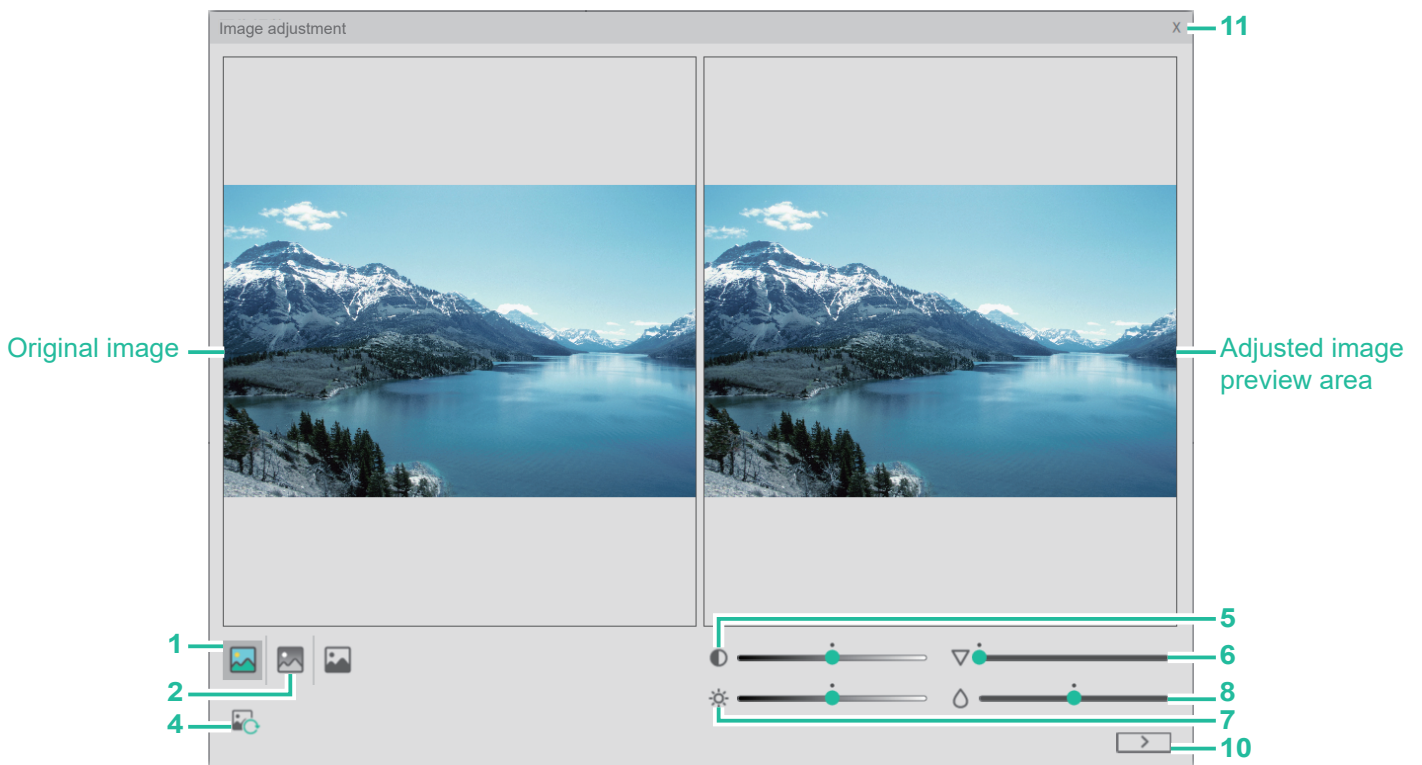

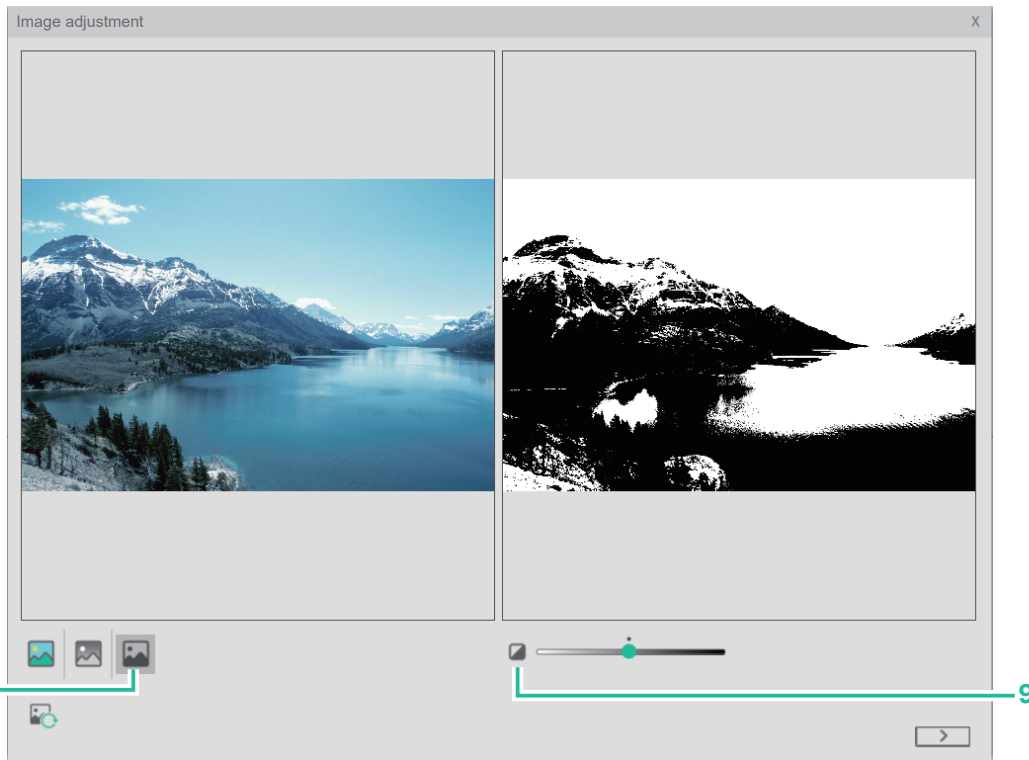

1. Color:

Generate coloroverlap satin stitch photo in stitch image.

2. Grayscale:

Generate grayscale Overlap satin stitch photo in stitch image.

3. Monochrome:

Generate monochrome Overlap satin stitch photo in stitch image.

4. Change picture file:

Change photo.

5. Contrast adjustment:

You can adjust the contrast of the photo to make the difference between light and dark more obvious.

6. Sharpness adjustment:

It can improve the sharpness of the photo, increase the contrast of the edge of the photo, and make the photo clearer.

7. Brightness Adjustment:

You can adjust the lightness and darkness of the photo.

8. Saturation Adjustment:

You can adjust the vividness of the color of the photo.

9. Black and white ratio adjustment:

Adjust the black and white ratio of monochrome photos.

10. Next step:

Press the next step button to enter the next step execution screen.

11. Close:

Press the close button to cancel the image output of Overlap satin stitch embroidery and return to the main window.

2. Image shape setting

Description:

Image shape setting.

Step:

1. Use the function buttons to edit the shape of the image, and use the mouse to click on the Bezier node to select the image position to be generated.

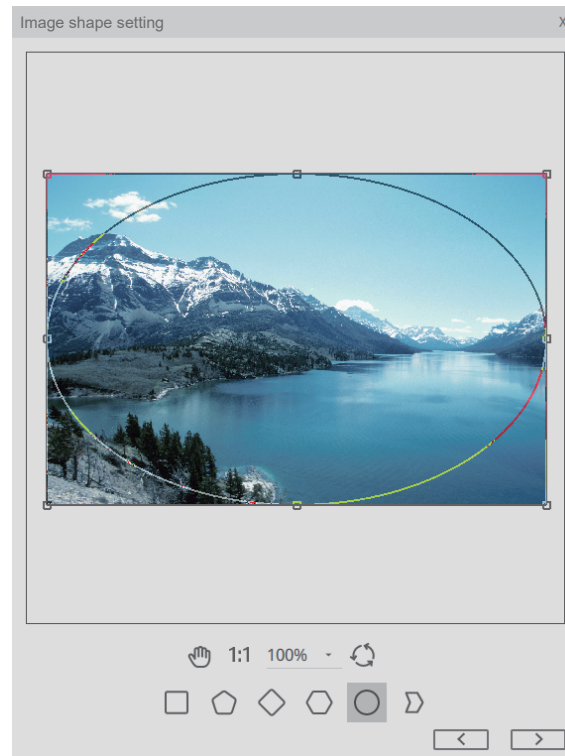

2. Click the <Next> button to enter the next step execution screen.

Function item description:

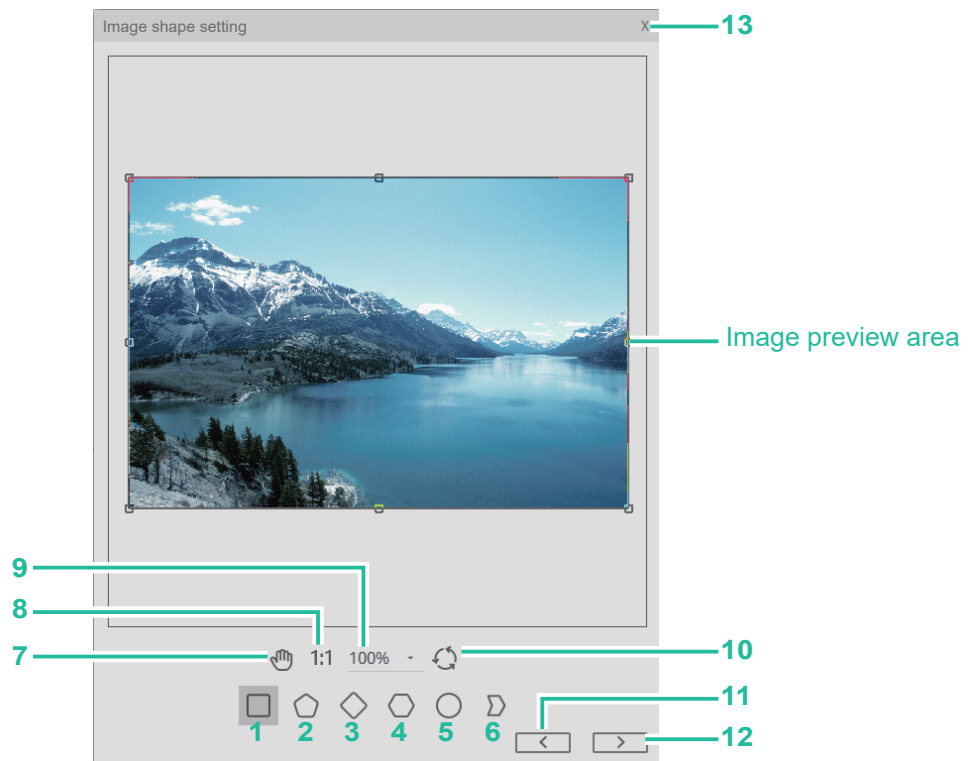

1. Rectangle:

The shape of the cropped image is a rectangle.

2. Pentagon:

The shape of the cropped image is a pentagon.

3. Rhombus:

The shape of the cropped image is rhombus.

4. Hexagon:

The shape of the cropped image is hexagon.



5. Oval:

The shape of the cropped image is oval.

6. Polygon:

The shape of the cropped image is in any shape. Use the mouse to click on the Bezier curve, you can directly add nodes on the line, directly click the control point, can be used with the delete button to delete and move nodes.

7. Move:

Move the position of the preview workspace. After clicking this function and moving the mouse to the workspace, the mouse icon will change to a moving icon , At this time, click and hold the screen to drag the screen directly. Click <Move> again, the mouse will cancel the move function, and the mouse will return to the selection tool .

8. Return to original ratio:

Click this function, and the display ratio of the work area on the screen will be restored to 1:1.

9. Viewing ratio:

According to the selected ratio, adjust the display ratio of the work area on the screen, and the maximum can be zoomed to 200%.

10. Reset:

Return to the initial screen of graphic cutting.

11. Previous step:

Press the previous step button to return to the previous step execution screen.

12. Next step:

Press the next step button to enter the next step execution screen.

13. Close:

Press the close button to cancel the image output of overlap satin stitch embroidery and return to the main window.

3. Image size setting

Description:

Image size setting.

Step:

1. Use the function bar to directly input the image file size, or use the <Zoom to Embroidery Frame> function to adjust the size.
The size adjustment range is 30.0mm~300.0mm, if the size is not within this range, the next step cannot be performed.
2. Click the <Next> button to enter the next step execution screen.

Function item description:

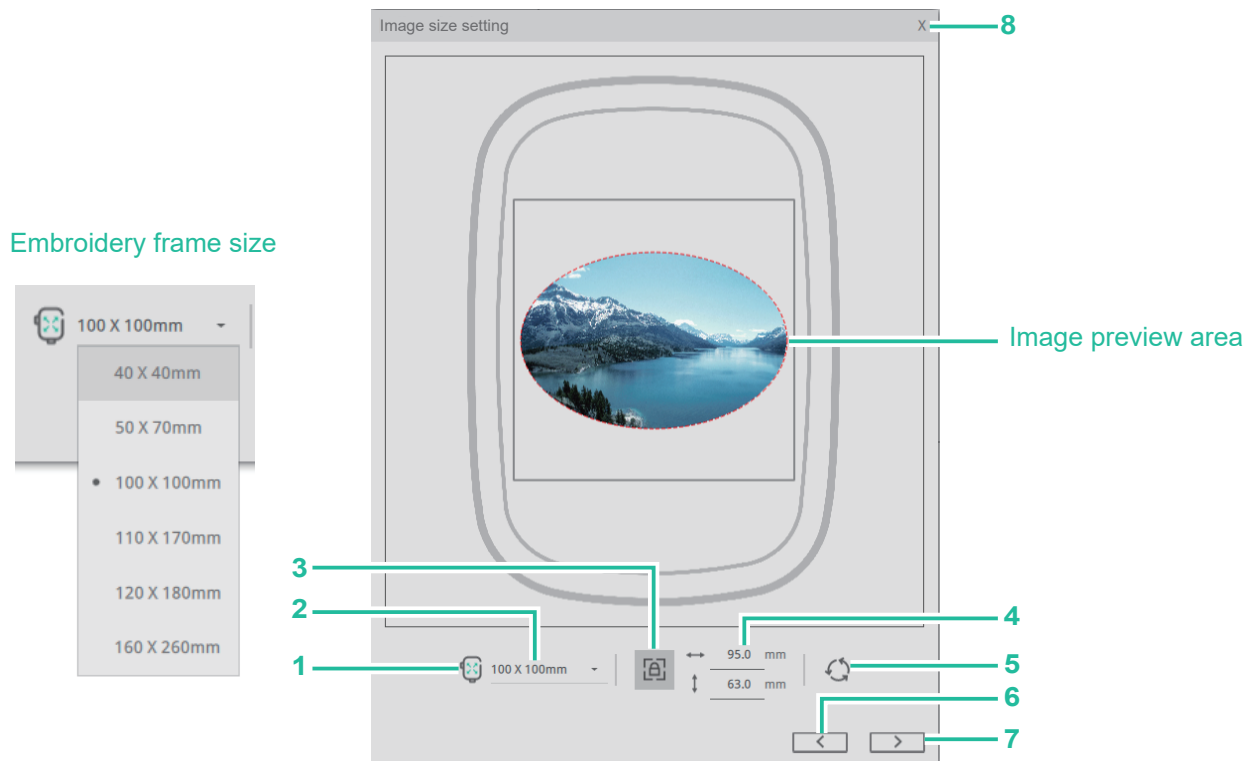

1. Zoom to the embroidery frame:

The size of the photo will fill the page proportionally according to the currently set frame size.

2. Change the size of the embroidery frame:

Click to change the size of the embroidery frame to change the current size of the frame.

3. Lock Ratio:

Lock or not lock the photo size ratio.

4. Size display and adjustment:

Directly enter the size at the width/height, and the size can be entered up to the first decimal place.

5. Reset:

Return to the original size of the image.

6. Previous step:

Press the previous step button to return to the previous step execution screen.

7. Next step:

Press the next step button to enter the next step execution screen.

8. Close:

Press the close button to cancel the image output of overlap satin stitch embroidery and return to the main window.

4. Set parameters / Color change

Description:

Set relevant parameters for the output overlap satin stitch embroidery.

Step:

1. Click <Embroidery Thread Brand List> to select the embroidery thread color brand.
2. There are 4 preset colors, and can not be adjusted. The color can be adjusted independently and the reserved color function can be set. When the color is set as reserved color, please adjust again the embroidery thread brand, thread color, brightness and contrast, the reserved color will remain unchanged.
3. The image can be based on the maximum density, line height, angle and whether to use outer frame zigzag hemming and other functions.
4. Click <Update Preview>, the stitch preview will display the parameter setting results.

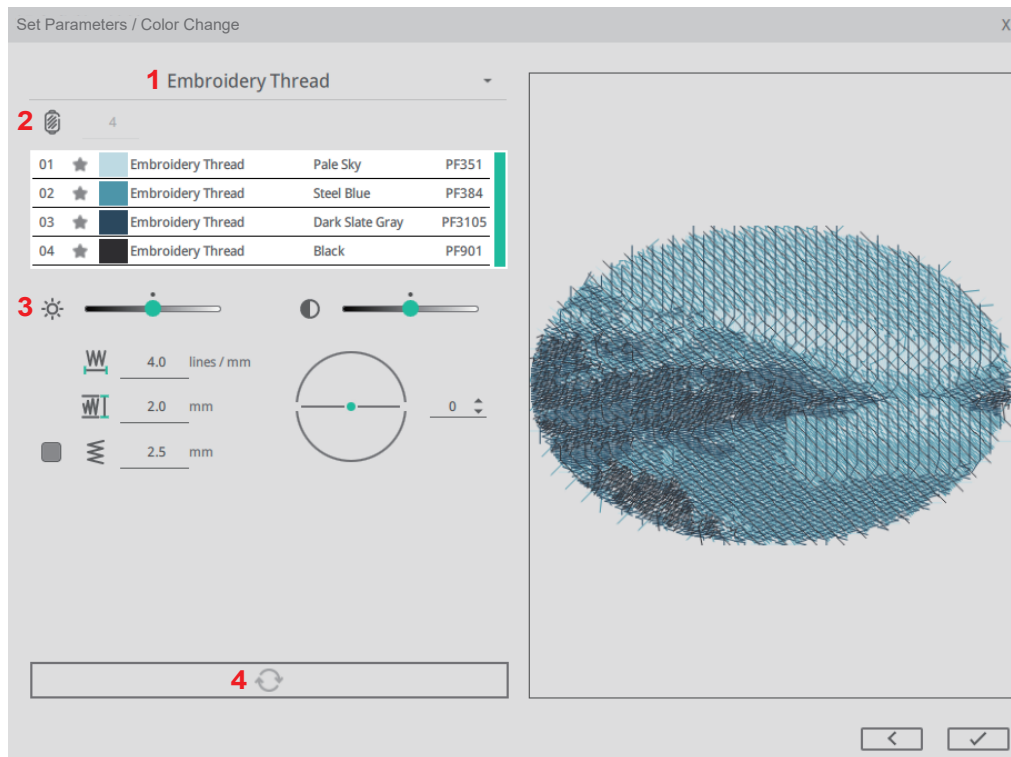

5. Click the ✓ button to complete the random stitch embroidery image and return to the main window.

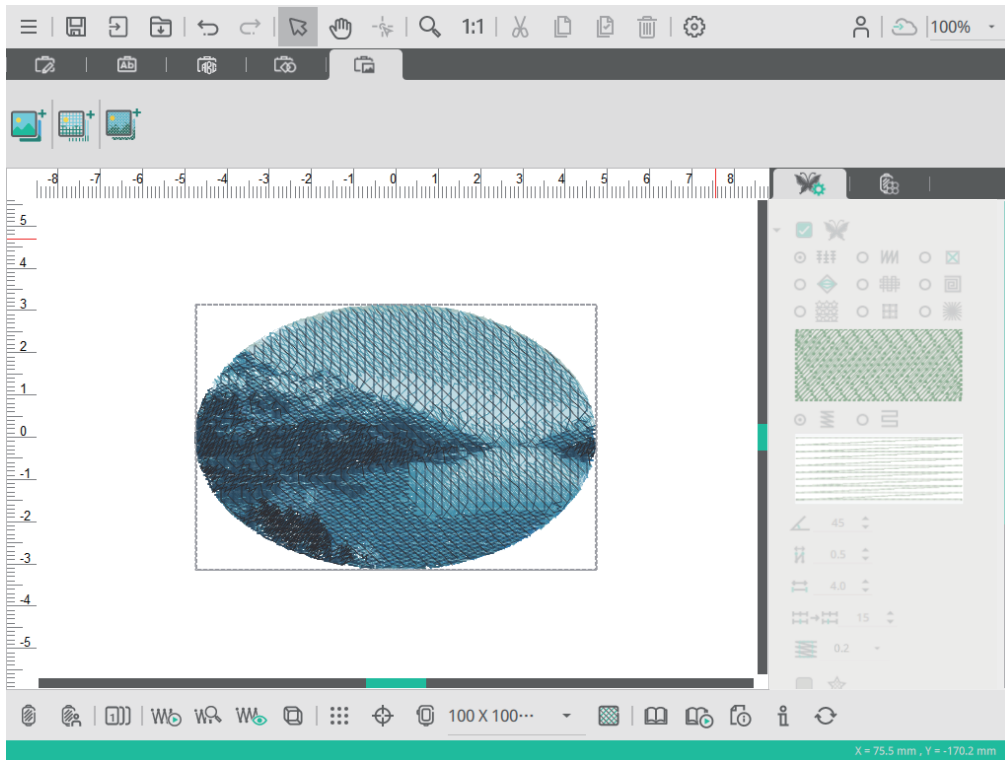

Function item description:

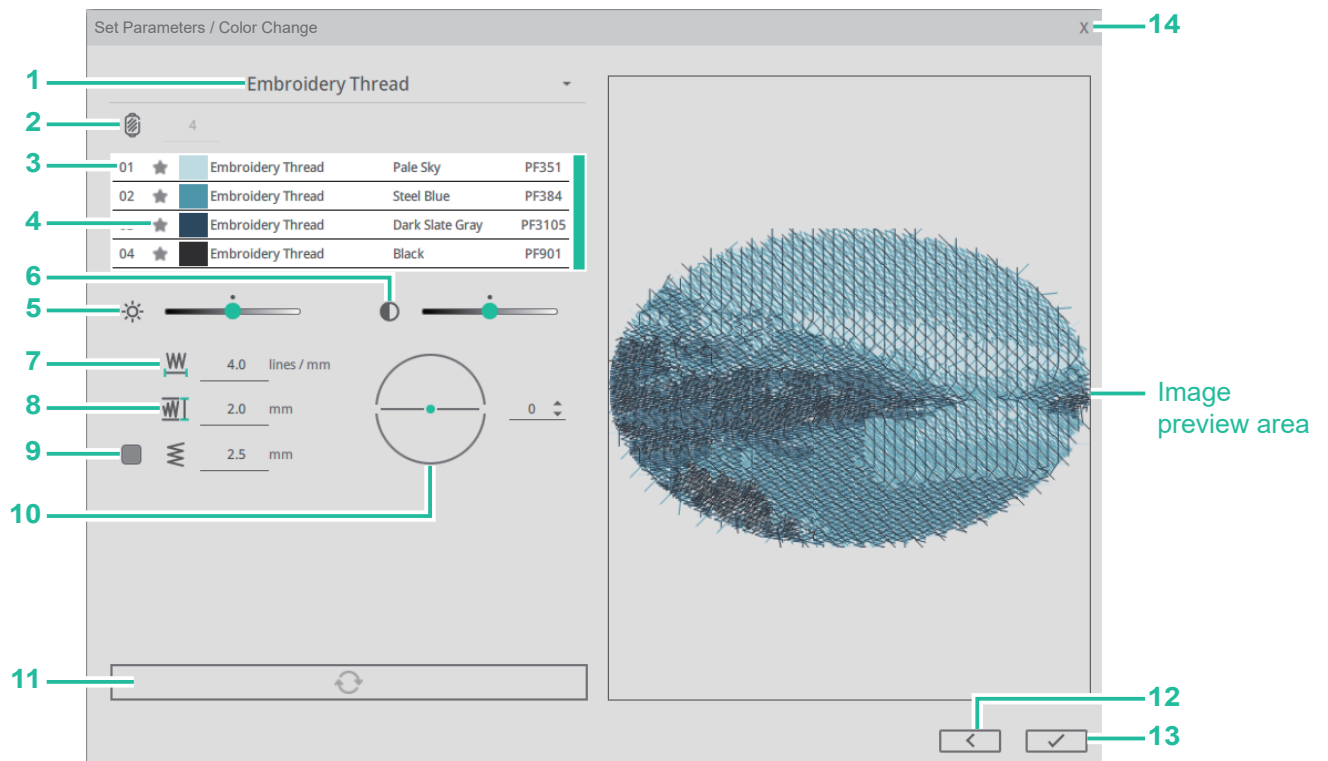

1. Thread color label list:

Press the thread color label setting to change the thread color label. When the reserved color function is activated, the color remains unchanged.

2. Number of colors:

The number of photo colors is preset to 4 colors and cannot be adjusted.

3. Color information:

Display the color, brand, color description and color number, and modify the thread color brand and thread color for a single color.

Place the mouse on the color column (at this time the color column is grayed out), use the left mouse button to quickly click twice, and the window for modifying the brand color will appear. Click on the thread color to modify the thread color brand/color. When the retain color function is activated, the thread color modification function cannot be entered.

4. Reserved color:

Press the function of retaining thread color, the icon will be represented by blue-green ★, and the current color can be retained. To cancel the reserve function, click the icon again, and the icon will be represented by gray ★. The setting can be canceled. When the function of retaining color is activated, the color changes brand or color number, the color remains unchanged.

5. Brightness adjustment:

Brightness adjustment can adjust the lightness and darkness of stitches. When the



reserved color function is activated, the color remains unchanged.

6. Contrast adjustment:

Contrast adjustment can adjust the contrast of stitches, making the difference between light and dark more obvious. When the reserved color function is activated, the color remains unchanged.

7. Maximum density:

Set the maximum linear density, preset 4. The larger the adjustment number, the denser the line wrinkle density. The lower the adjustment number, the thinner the line wrinkle density.

8. Line height:

Set the line spacing, default 2. The larger the adjustment number, the larger the line spacing. The smaller the adjustment number, the smaller the line spacing.

9. Outer frame zigzag hemming:

Set whether to add zigzag to the outer frame of the image, default/uncheck, when checked, default 2.5mm.

10. Angle:

Set stitch angle, default 0. The adjustment range is 0~179. You can enter a value or press the up and down arrows on the right to adjust, or press and hold the graphic icon to rotate and adjust.

11. Update preview:

Press the <Update preview> button to regenerate a new stitch icon according to the adjusted parameters.

12. Previous step:

Press the previous step button to return to the previous step execution screen.

13. Completion:

Press the Finish button to produce image stitches of overlap satin stitch embroidery and return to the main window.

14. Close:

Press the close button to cancel the image output of overlap satin stitch embroidery and return to the main window.

● Photo Stitch-Sub module 3



Cross stitch

Path: <Cross stitch>

Description:

Click on the icon of Cross stitch embroidery to create photo stitch images of Crossed stitch embroidery.

Suggestions for using photos:

- The theme is clear and occupies a large proportion of the whole picture.
- The image should not be gray and dark. The brightness, contrast, and saturation can be adjusted in due course.
- The photo pixel is recommended not to be lower than 500 pixels.

1. Image adjustment

Description:

After the image is selected, you can choose the style mode you want to produce, and make image adjustments for the image.

Step:

1. Click <Cross stitch embroidery module>  and select the image to be made into Cross stitch embroidery.

If you want to re-select the image, you can use the <Change Image File> function to re-select the image.

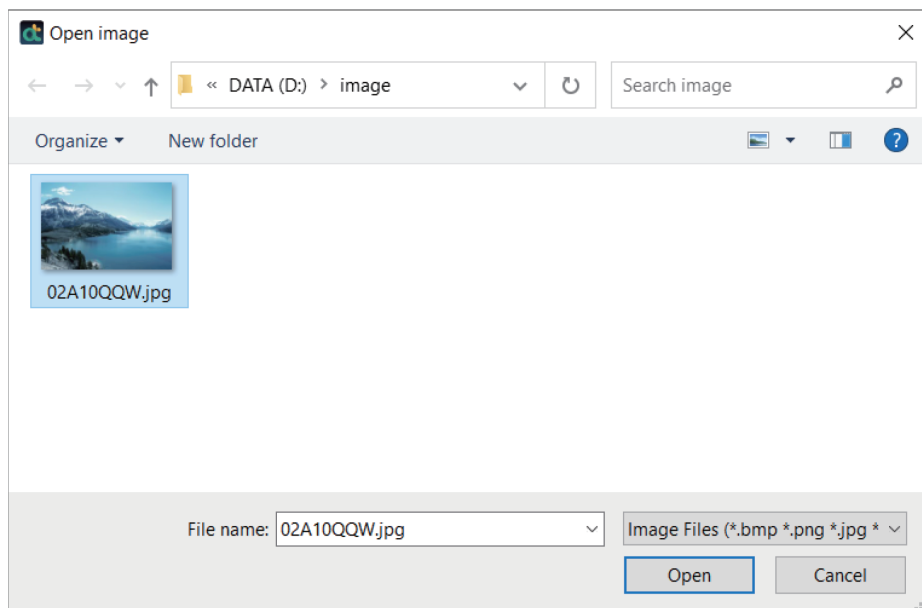

2. Select image mode, there are three modes (color/grayscale/monochrome) to choose from.



3. Click the <Next> button to enter the next step execution screen.

Function item description:

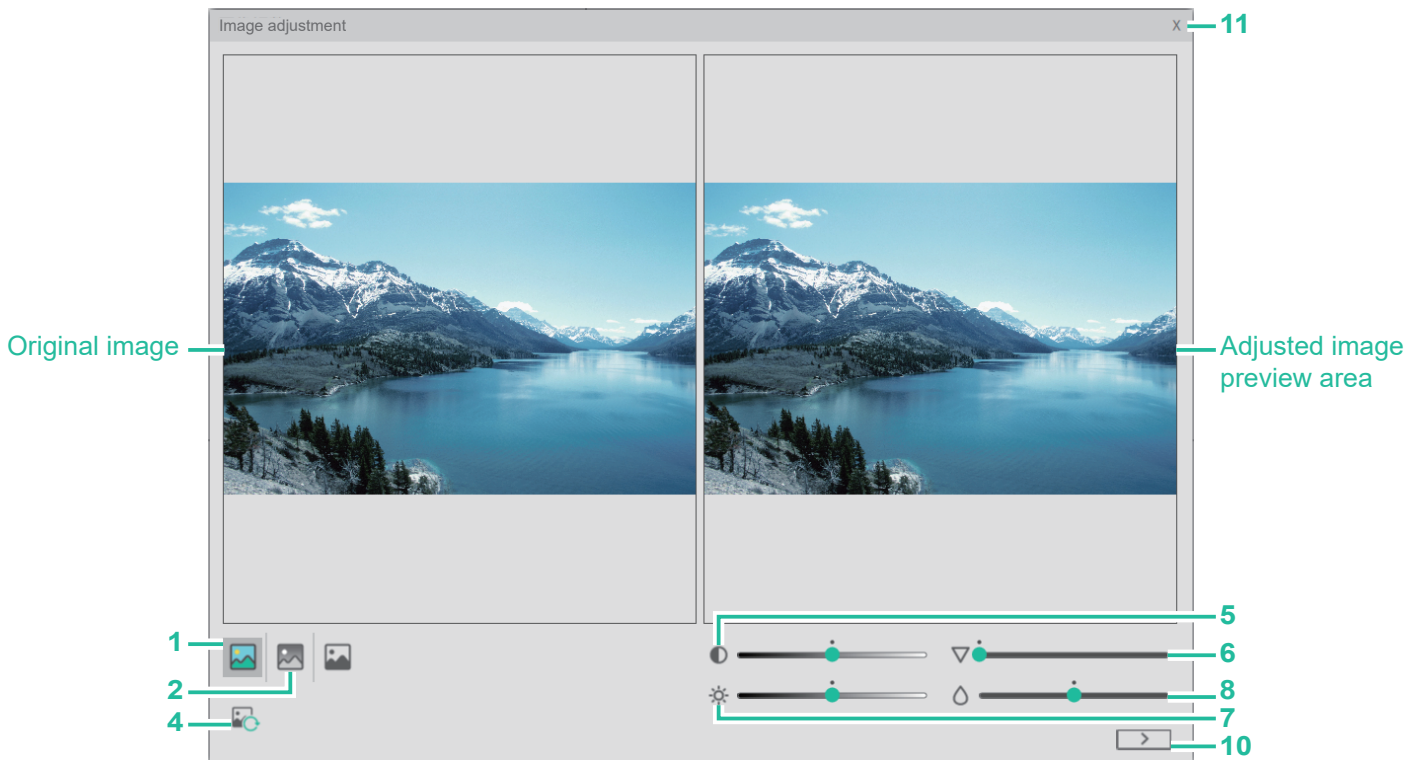

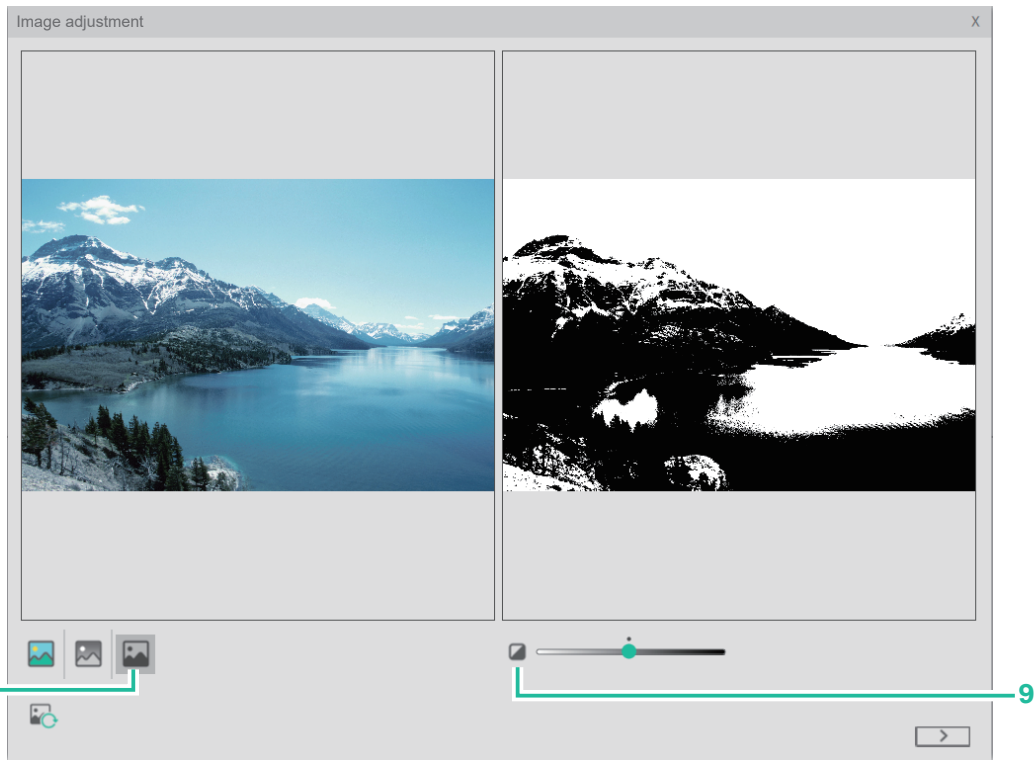

1. Color:

Generate color Cross stitch photo in stitch image.

2. Grayscale:

Generate grayscale Cross stitch photo in stitch image.

3. Monochrome:

Generate monochrome Cross stitch photo in stitch image.

4. Change picture file:

Change photo.

5. Contrast adjustment:

You can adjust the contrast of the photo to make the difference between light and dark more obvious.

6. Sharpness adjustment:

It can improve the sharpness of the photo, increase the contrast of the edge of the photo, and make the photo clearer.

7. Brightness Adjustment:

You can adjust the lightness and darkness of the photo.

8. Saturation Adjustment:

You can adjust the vividness of the color of the photo.

9. Black and white ratio adjustment:

Adjust the black and white ratio of monochrome photos.

10. Next step:

Press the next step button to enter the next step execution screen.

11. Close:

Press the close button to cancel the image output of Cross stitch embroidery and return to the main window.

2. Image shape setting

Description:

Image shape setting.

Step:

1. Use the function buttons to edit the shape of the image, and use the mouse to click on the Bezier node to select the image position to be generated.

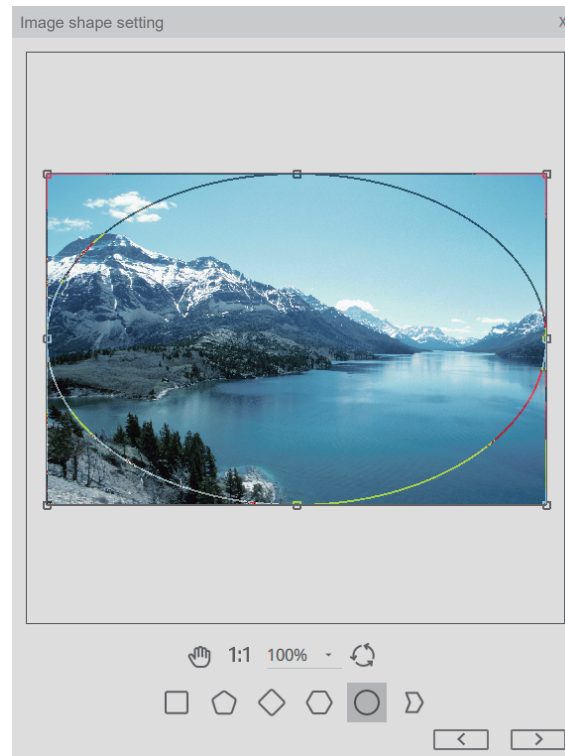

2. Click the <Next> button to enter the next step execution screen.

Function item description:

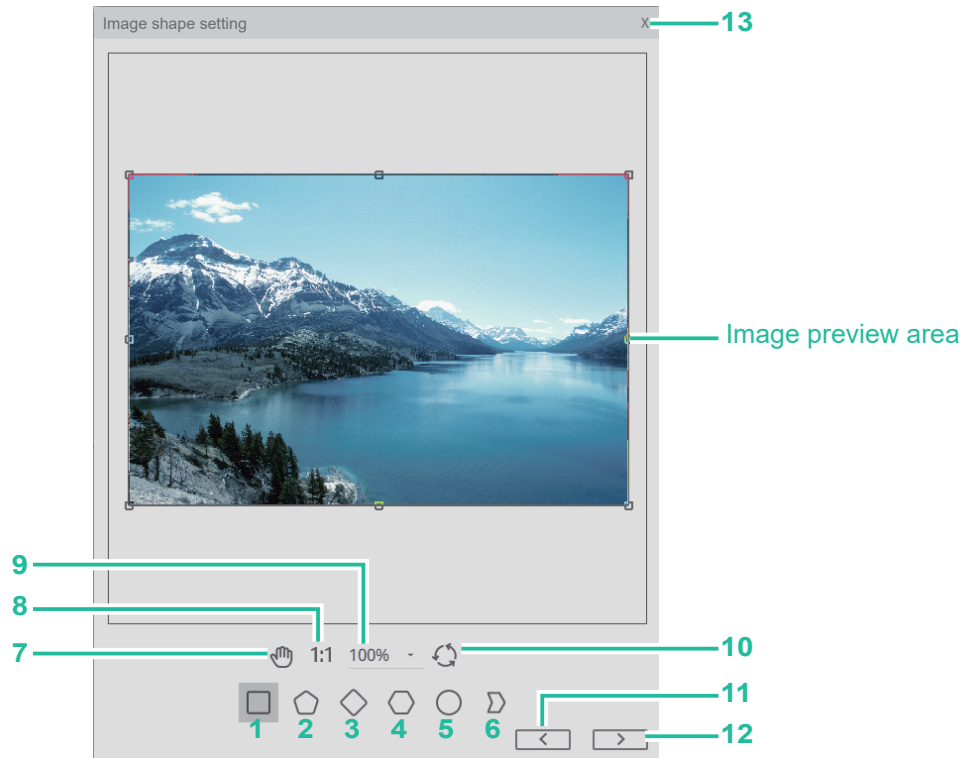

1. Rectangle:

The shape of the cropped image is a rectangle.

2. Pentagon:

The shape of the cropped image is a pentagon.

3. Rhombus:

The shape of the cropped image is rhombus.

4. Hexagon:

The shape of the cropped image is hexagon.



5. Oval:

The shape of the cropped image is oval.

6. Polygon:

The shape of the cropped image is in any shape. Use the mouse to click on the Bezier curve, you can directly add nodes on the line, directly click the control point, can be used with the delete button to delete and move nodes.

7. Move:

Move the position of the preview workspace. After clicking this function and moving the mouse to the workspace, the mouse icon will change to a moving icon , at this time, click and hold the screen to drag the screen directly. Click <Move> again, the mouse will cancel the move function, and the mouse will return to the selection tool .



8. Return to original ratio:

Click this function, and the display ratio of the work area on the screen will be restored to 1:1.

9. Viewing ratio:

According to the selected ratio, adjust the display ratio of the work area on the screen, and the maximum can be zoomed to 200%.

10. Reset:

Return to the initial screen of graphic cutting.

11. Previous step:

Press the previous step button to return to the previous step execution screen.

12. Next step:

Press the next step button to enter the next step execution screen.

13. Close:

Press the close button to cancel the image output of Cross stitch embroidery and return to the main window.

3. Image size setting

Description:

Image size setting.

Step:

1. Use the function bar to directly input the image file size, or use the <Zoom to Embroidery Frame> function to adjust the size.
The size adjustment range is 30.0mm~300.0mm, if the size is not within this range, the next step cannot be performed.
2. Click the <Next> button to enter the next step execution screen.

Function item description:

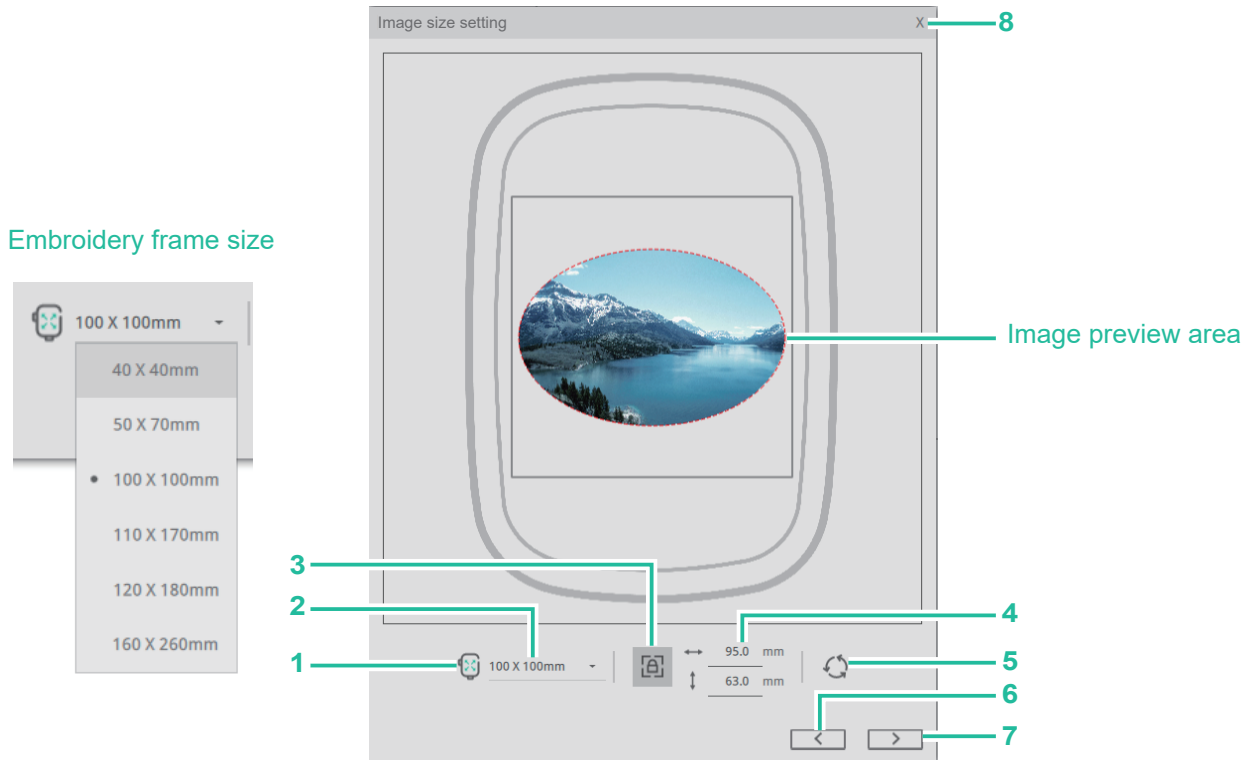

1. Zoom to the embroidery frame:

The size of the photo will fill the page proportionally according to the currently set frame size.

2. Change the size of the embroidery frame:

Click to change the size of the embroidery frame to change the current size of the frame.

3. Lock Ratio:

Lock or not lock the photo size ratio.

4. Size display and adjustment:

Directly enter the size at the width/height, and the size can be entered up to the first decimal place.

5. Reset:

Return to the original size of the image.

6. Previous step:

Press the previous step button to return to the previous step execution screen.

7. Next step:

Press the next step button to enter the next step execution screen.

8. Close:

Press the close button to cancel the image output of Cross stitch embroidery and return to the main window.

4. Set parameters / Color change

Description:

Set relevant parameters for the output Cross stitch embroidery.

Step:

1. Click <Embroidery Thread Brand List> to select the embroidery thread color brand.
2. Enter the number of embroidery thread colors, 8 colors are preset, the adjustable range is 4~50 colors. After thread brand and color are selected, the color can be adjusted independently and the reserved color function can be set. When the color is set as reserved color, please adjust again the embroidery thread brand, thread color, brightness and contrast, the reserved color will remain unchanged.
3. The image can be set according to the effect such as size, number of times, whether to use outer frame zigzag hemming , whether to change the cross stitch to a unified grid, etc.
4. Click <Update Preview>, the stitch preview will display the parameter setting results.

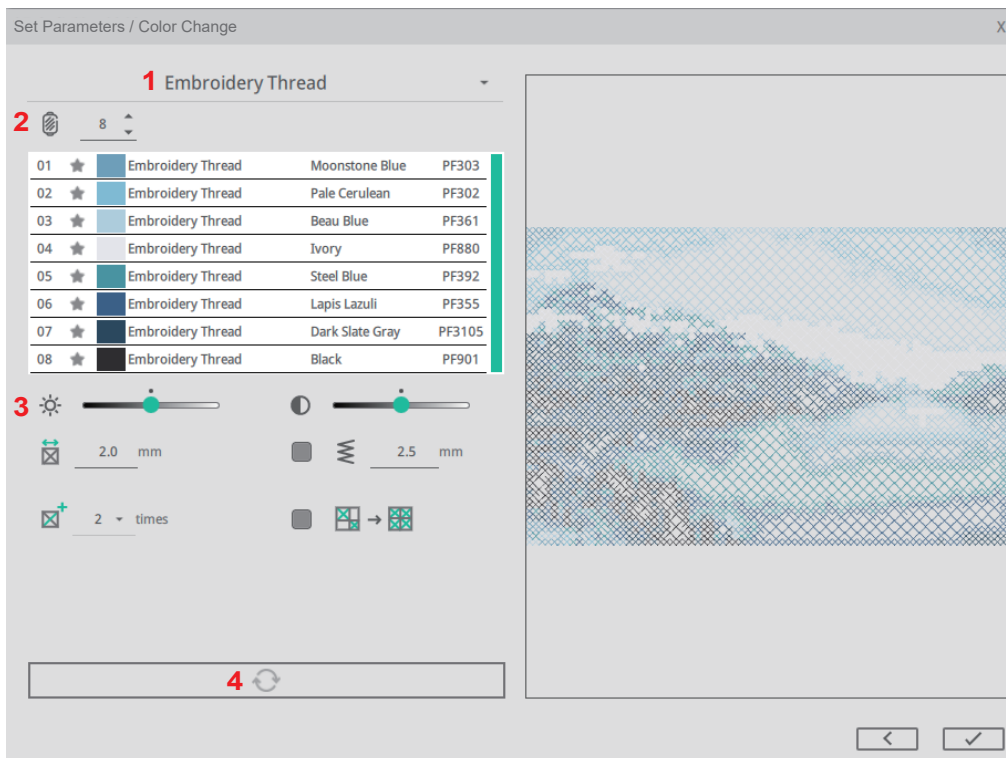

5. Click the  button to complete the random stitch embroidery image and return to the main window.

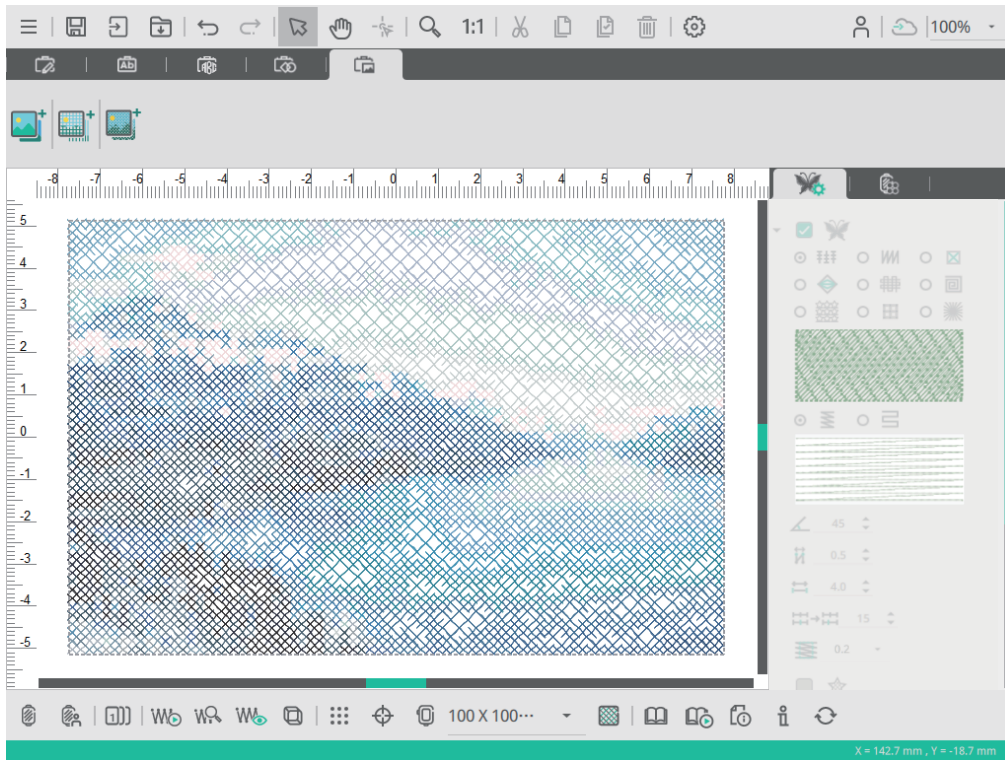

Function item description:

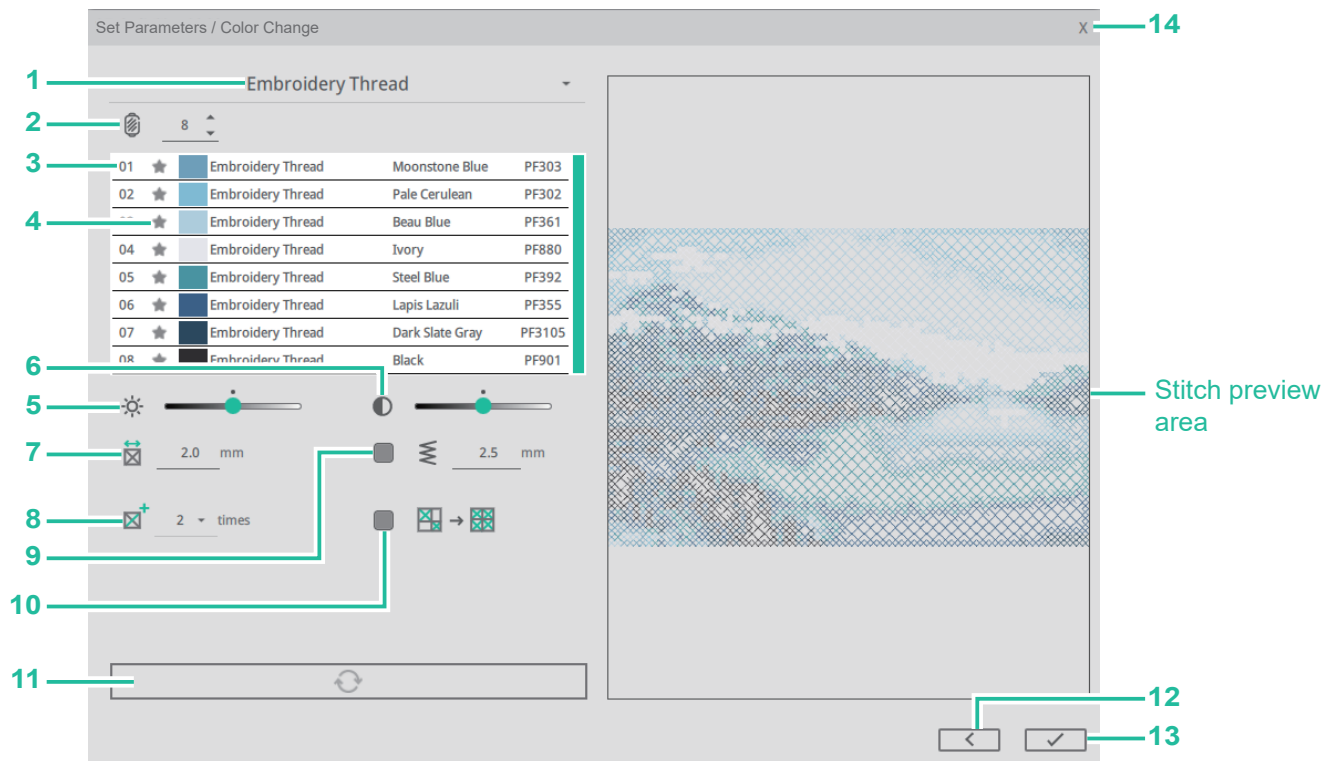

1. Thread color label list:

Press the thread color label setting to change the thread color label. When the reserved color function is activated, the color remains unchanged.

2. Number of colors:

The number of photo colors is preset to 8 colors, the adjustable range is 4~50 colors. The actual output color number will be expressed according to the calculation result of the image file. The number of colors can be directly input by the keys, or the up and down keys can be used to increase or decrease the color.

When the reserved color function is enabled, the minimum number of colors is the number of reserved colors.

3. Color information:

Display the color, brand, color description and color number, and modify the thread color brand and thread color for a single color.

Place the mouse on the color column (at this time the color column is grayed out), use the left mouse button to quickly click twice, and the window for modifying the brand color will appear. Click on the thread color to modify the thread color brand/color. When the retain color function is activated, the thread color modification function cannot be entered.

4. Reserved color:

Press the function of retaining thread color, the icon will be represented by blue-green ★, and the current color can be retained. To cancel the reserve function, click the icon again, and the icon will be represented by gray ★. The setting can be canceled. When the



function of retaining color is activated, the color changes brand or color number, the color remains unchanged.

5. Brightness adjustment:

Brightness adjustment can adjust the lightness and darkness of stitches. When the reserved color function is activated, the color remains unchanged.

6. Contrast adjustment:

Contrast adjustment can adjust the contrast of stitches, making the difference between light and dark more obvious. When the reserved color function is activated, the color remains unchanged.

7. Cross stitch size:

Set the cross stitch size, preset 2.0, adjustable range 1.5~5.0 mm, jump value 0.1.

8. Wiring times:

Set image wiring times, preset/2 times, adjustable range 2, 4, 6 times.

9. Outer frame zigzag hemming:

Set whether to add zigzag to the outer frame of the image, default/uncheck, when checked, default 2.5mm.

10. Use all cross stitch style:

Change the image style, preset/size grid, and adjust it to a unified grid.

11. Update preview:

Press the <Update preview> button to regenerate a new stitch icon according to the adjusted parameters.

12. Previous step:

Press the previous step button to return to the previous step execution screen.

13. Completion:

Press the Finish button to produce image stitches of Cross stitch embroidery and return to the main window.

14. Close:

Press the close button to cancel the image output of Cross stitch embroidery and return to the main window.

The background is a dark blue gradient with several overlapping, wavy, layered shapes in lighter shades of blue and black, creating a sense of depth and movement. The shapes are organic and fluid, resembling liquid or smoke. The word "Others" is centered in the middle of the image in a white, bold, sans-serif font.

Others

System Requirements

● Microsoft Windows

- PC with intel processor or equivalent (2GHz or higher)
- Microsoft Windows 7, 8, 10
- 4 GB RAM
- 200 MB hard disk space for program installation
- Screen resolution 1024x768, 16 million colors
- Keyboard, Mouse

● Apple macOS

- OS X 10.13 or later
- 4 GB RAM
- 200 MB hard disk space for program installation
- Screen resolution 1024x768, 16 million colors
- Keyboard, Mouse

The background is a dark blue gradient with several overlapping, wavy, layered shapes in lighter shades of blue and teal, creating a sense of depth and movement. The shapes are organic and fluid, resembling liquid or smoke. The text is centered in a clean, white, sans-serif font.

Embroidery Pattern Chart

Embroidery Pattern Chart



Floral & Plant



01001

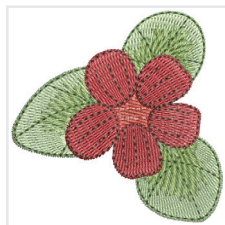

01002



01003



01004



01005

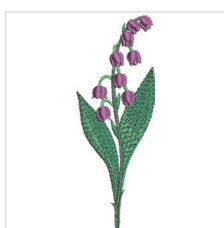

01006



01007



01008



01009



01010



Animal



02001



02002



02003

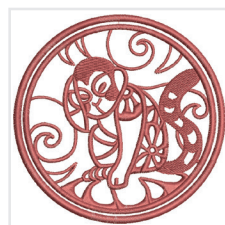

02004



02005

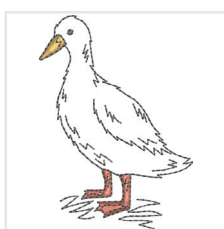

02006

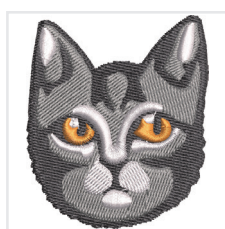

02007

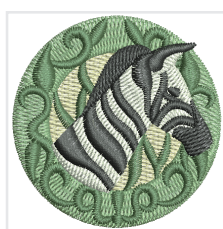

02008



02009

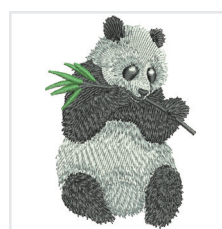

02010



Frame



05001

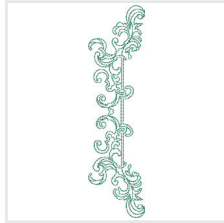

05002

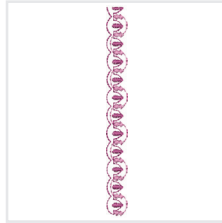

05003



05004

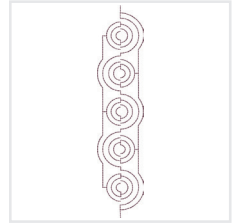

05005



05006

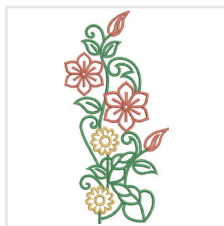

05007



05008



05009



Totem

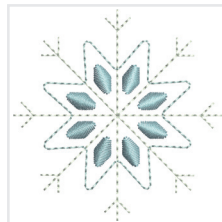

06001

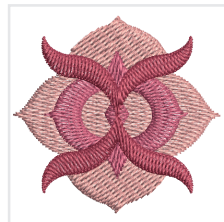

06002

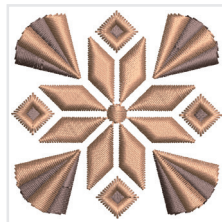

06003

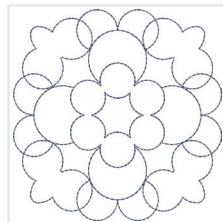

06004

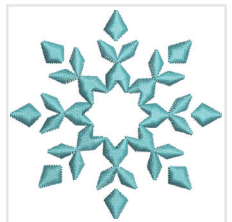

06005



06006

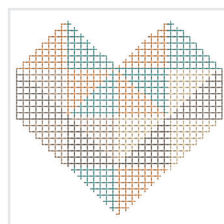

06007



06008



06009



06010



06011

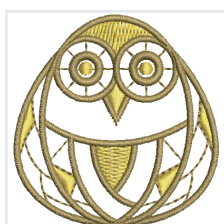

06012

 Sport



09001



09002



09003



09004



09005



09006



09007



09008

 Christmas



09001



09002



09003



09004

 Halloween



09001



09002



09003

 Scenery



22001



22002



22003

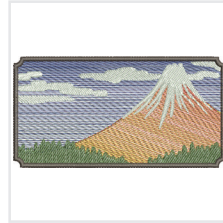

22004



22005



22006

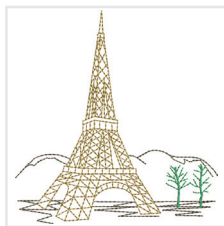

22007



22008



22009



22010

 Houseware



24001

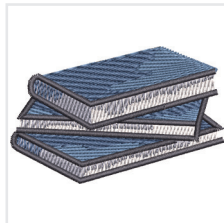

24002



24003



24004

